

## TRAVELLER SPINNING WHEEL DOUBLE DRIVE

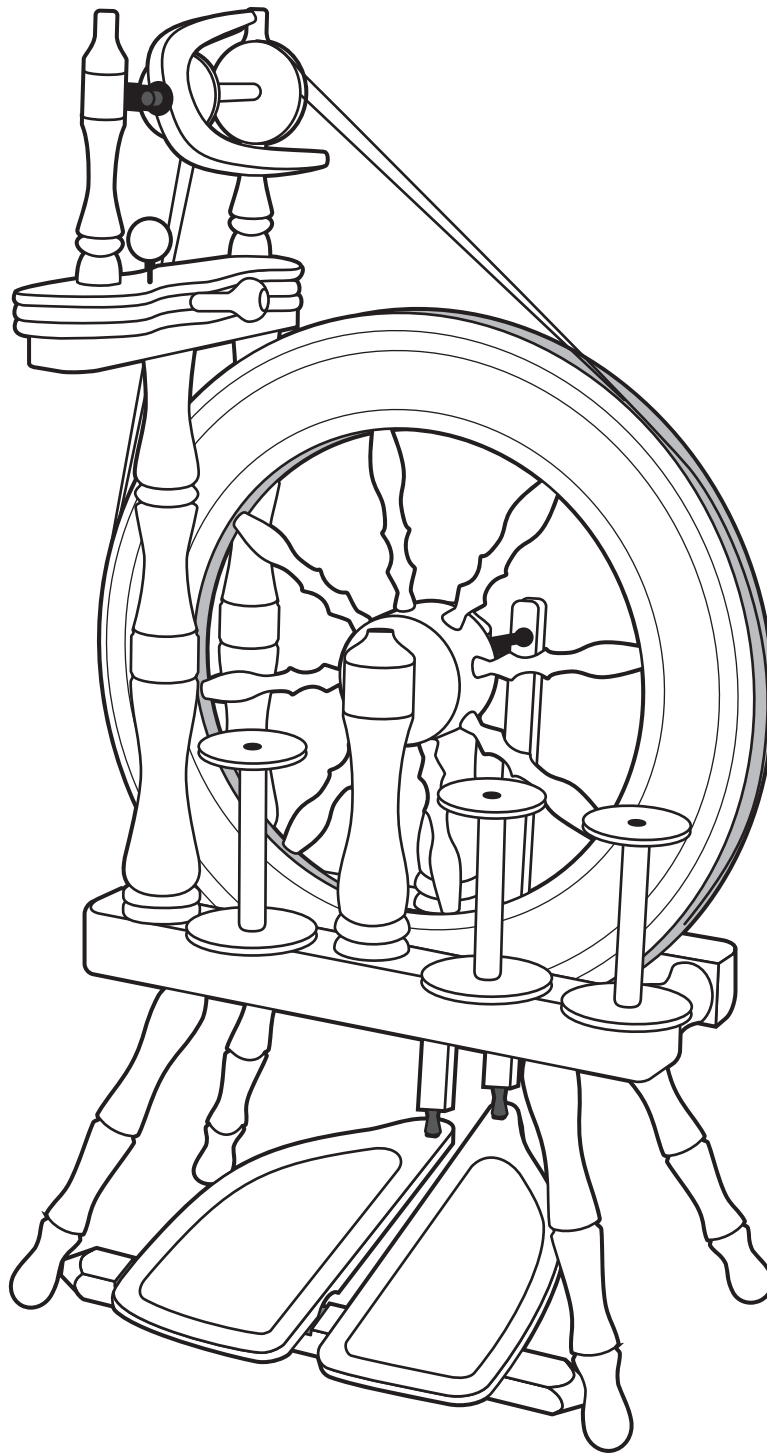

TVDTD20102014V9

# ASSEMBLY INSTRUCTIONS FOR THE ASHFORD TRAVELLER SPINNING WHEEL -Double Drive-

Before commencing, please read these instructions completely, identify the parts and note the assembly sequence.

Remove any sharp corners or edges and smooth the surface of the wood with the sand paper provided. We recommend that the wood surfaces be waxed or sealed before assembly. This protects the kiln dried wood from the climatic changes and prevents it getting dirty or stained. The Silver Beech tree is a native of New Zealand and has a lovely variety

of colour and grain. For a silky smooth matt finish, use the Ashford Wax Finish to enhance the natural colours and character of this timber.

If you are assembling your spinning wheel on a table, we recommend you protect the surface with a towel, blanket or cardboard. Ashford spinning wheels are also available factory finished in clear lacquer.

## Tools Required



Screwdriver



Hammer



Allen Key

(including)



Scissors



CANDLE WAX



OIL

## Hints

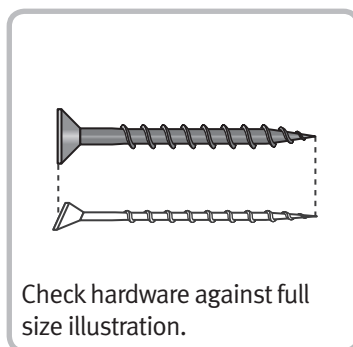

Check hardware against full size illustration.

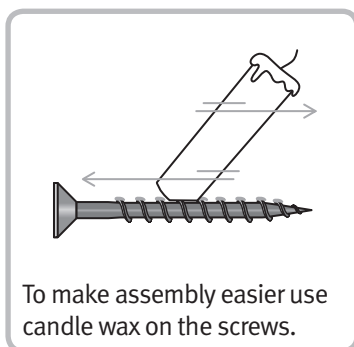

To make assembly easier use candle wax on the screws.



Check the directions carefully.

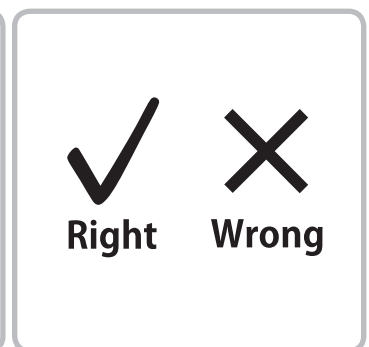

Right

Wrong

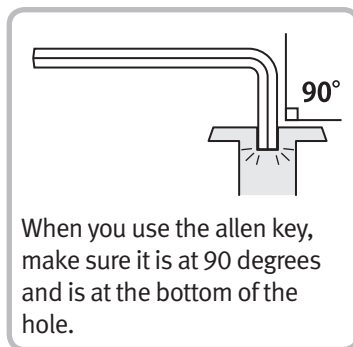

When you use the allen key, make sure it is at 90 degrees and is at the bottom of the hole.

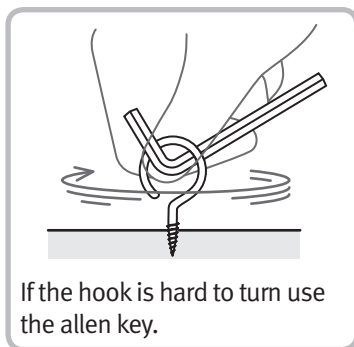

If the hook is hard to turn use the allen key.

## More Information



### How-to videos on You Tube

Watch our how-to videos on You Tube.  
[www.youtube.com/user/AshfordHandicrafts](http://www.youtube.com/user/AshfordHandicrafts)



### Facebook

Join us on facebook.  
[www.facebook.com/ashford.wheels.looms](http://www.facebook.com/ashford.wheels.looms)

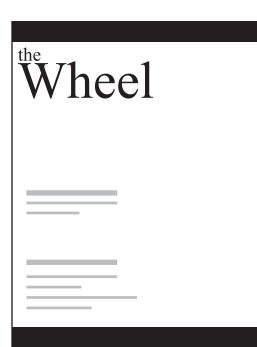

### The Wheel Magazine

Ashford's annual fibrecraft magazine. Spinning, weaving, felting, dyeing and knitting projects, patterns and articles from around the world. To receive the glossy version delivered to you, subscribe at:  
[www.ashford.co.nz/subscribe](http://www.ashford.co.nz/subscribe)

# Real Scale Hardware List

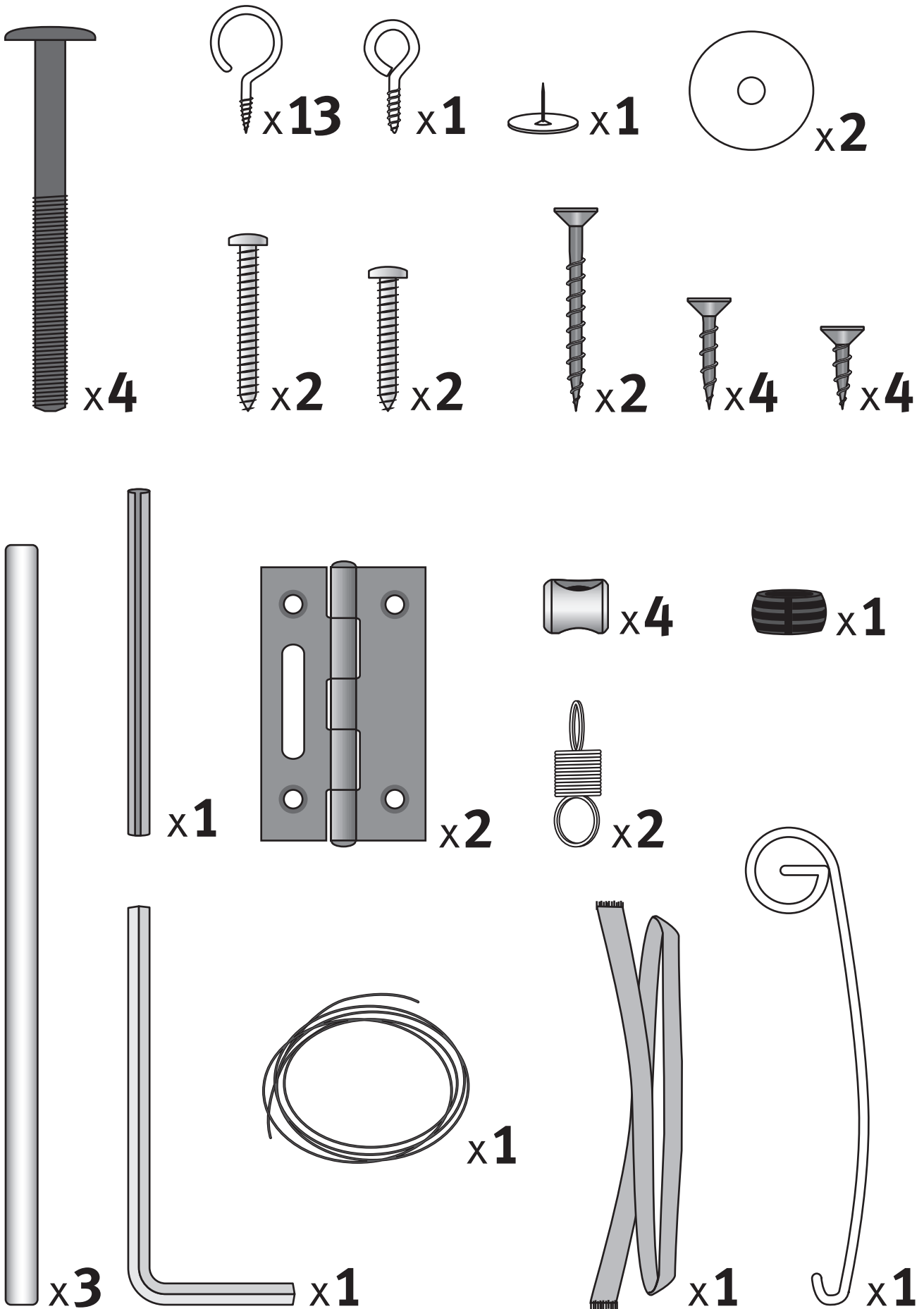



Thread 12 hooks into the flyer.

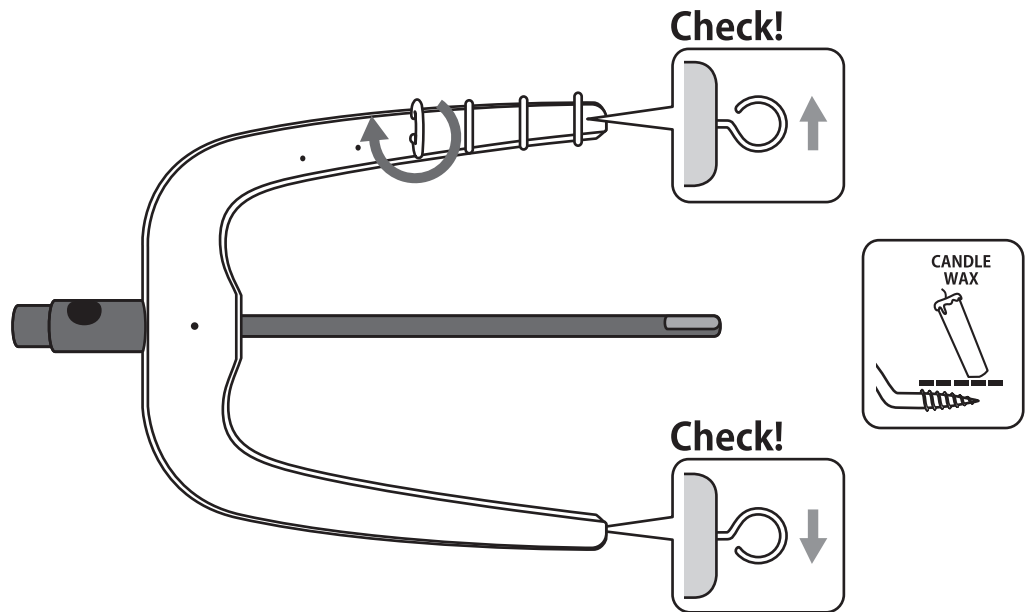

Secure the 2 hinges to the maiden bar.

Note the position of the slot in the hinge.

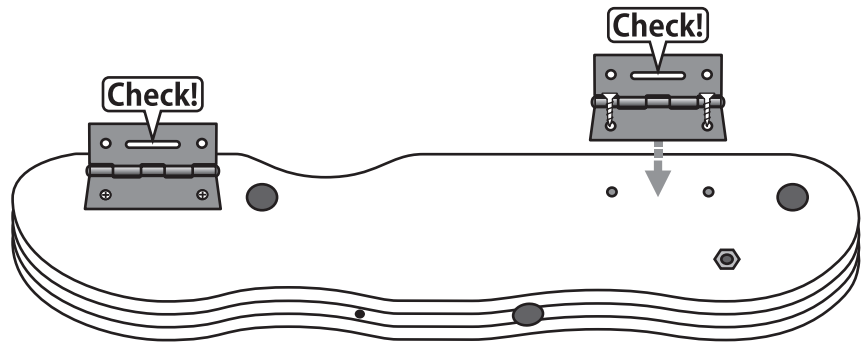
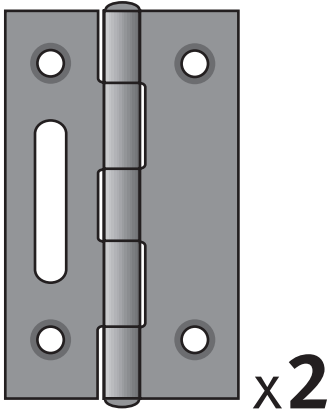

Assemble the flyer unit. Check the shape of the nylon bearing on each maid upright, then insert into the correct hole. Insert the drive belt adjusting knob into the maiden bar, turn until the end just protrudes.

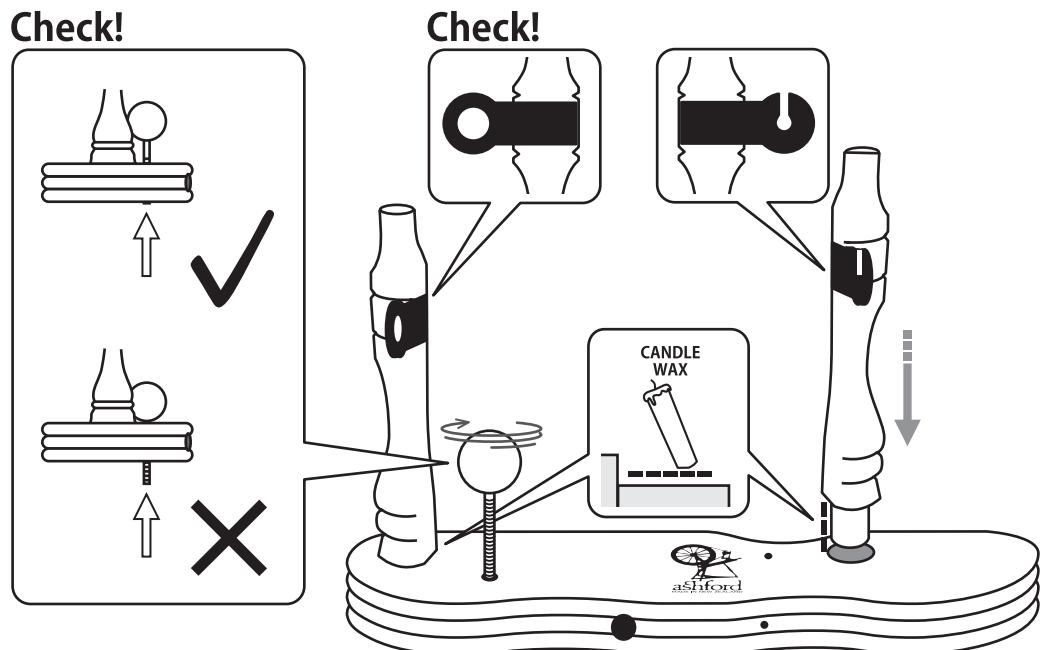



Check the angle of nylon bearings and then secure the maid uprights with screws and washers. Do not overtighten. The maid uprights may be twisted to remove the bobbin. Thread the screw eye into the side of the maiden bar.

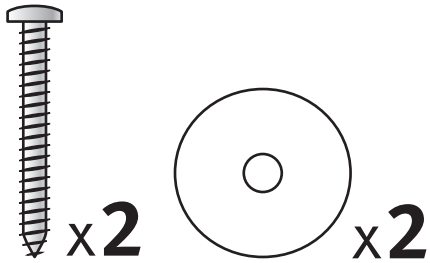

**Check!**

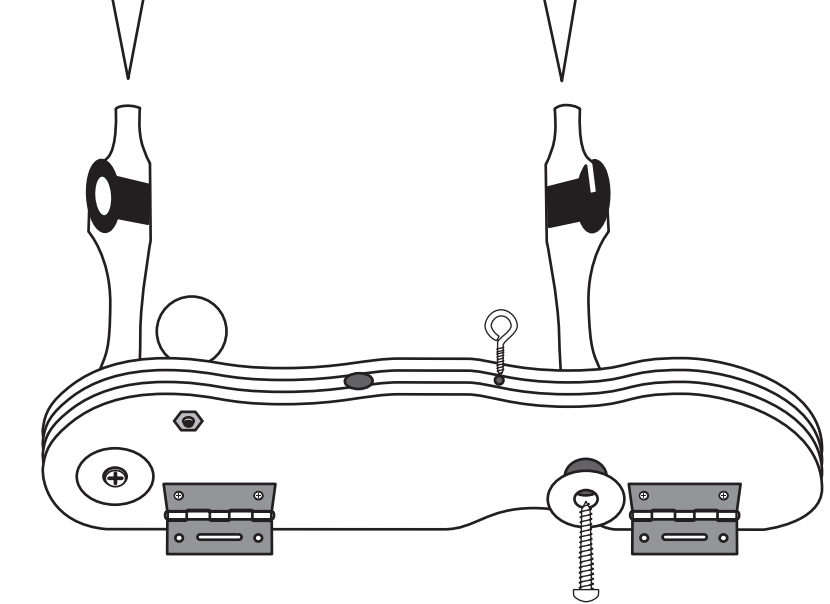
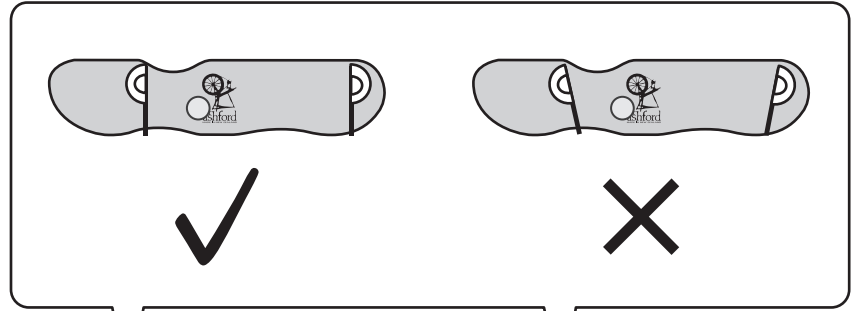

Slide a bobbin onto the flyer followed by the whorl. Then locate the flyer into the bearings. Thread the screw hook into the top.

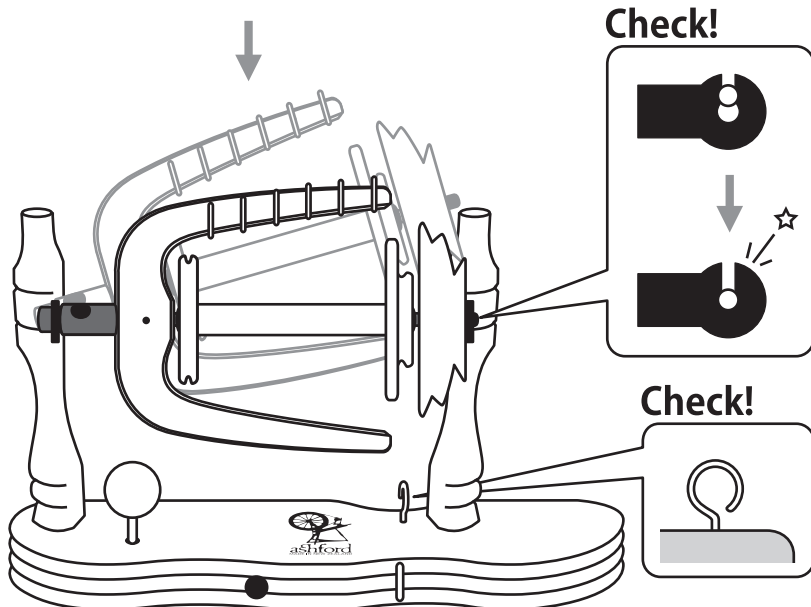
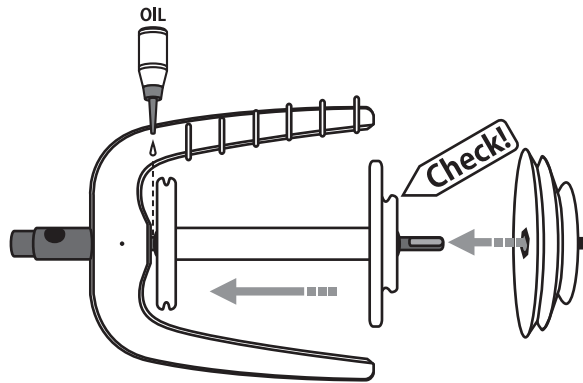



Attach the brake band. Thread it through the screw eye and then tie the springs as illustrated.

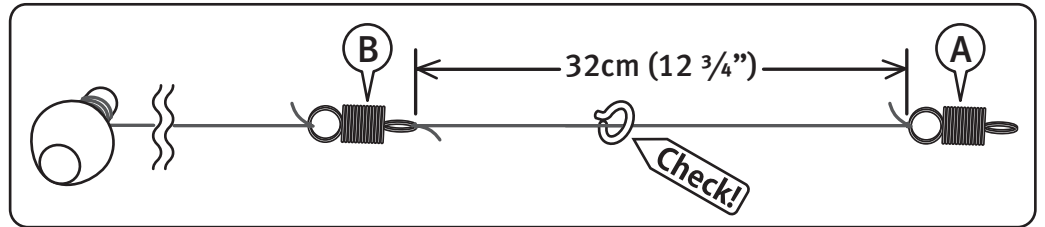
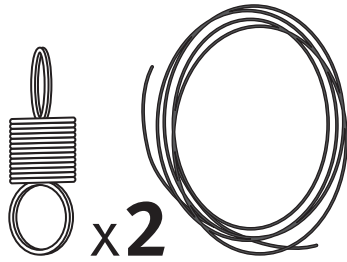
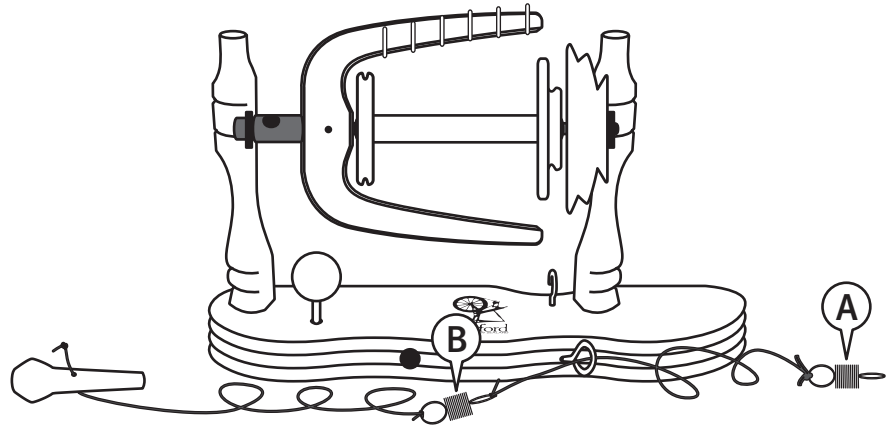

Use the brake band option when you spin with scotch tension. Otherwise store it as illustrated.

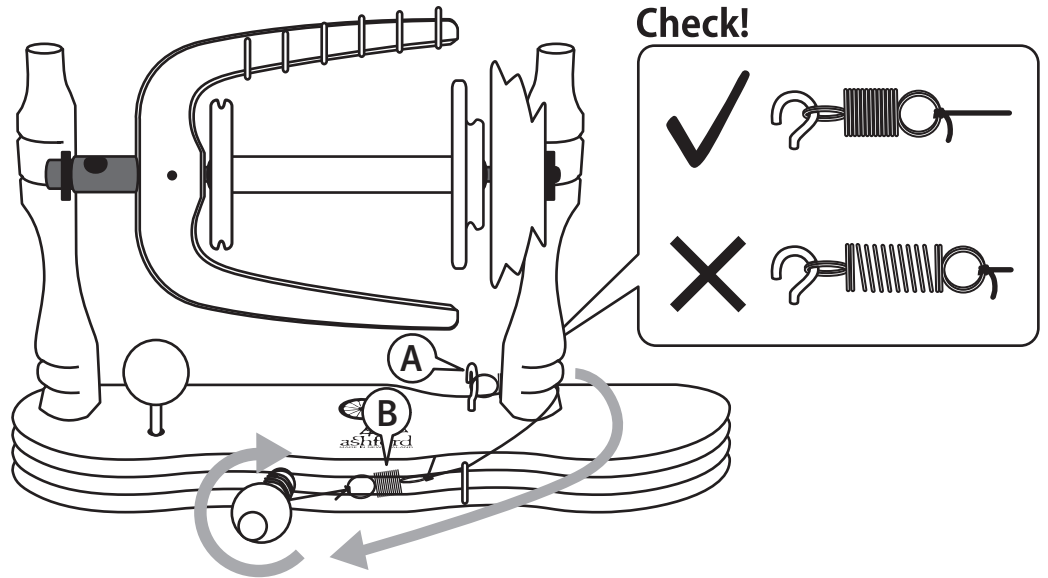

Check the holes in the base for the maiden bar supports are on the left hand side. Wax the steel rods in the treadle rail.

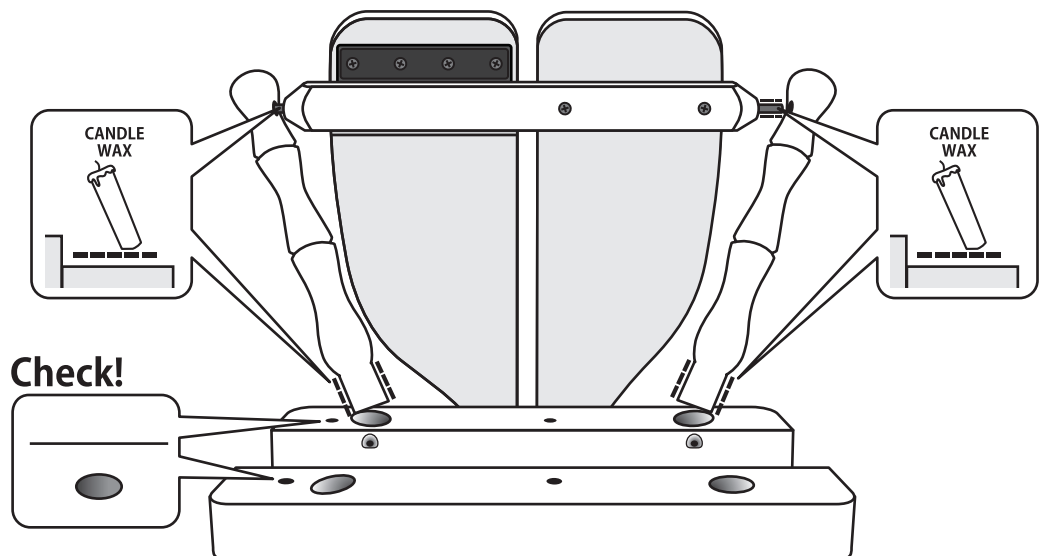



Locate the treadle rail into the holes in 2 legs. Check the treadle rail rotates freely. Then tap these legs to the bottom of the holes.

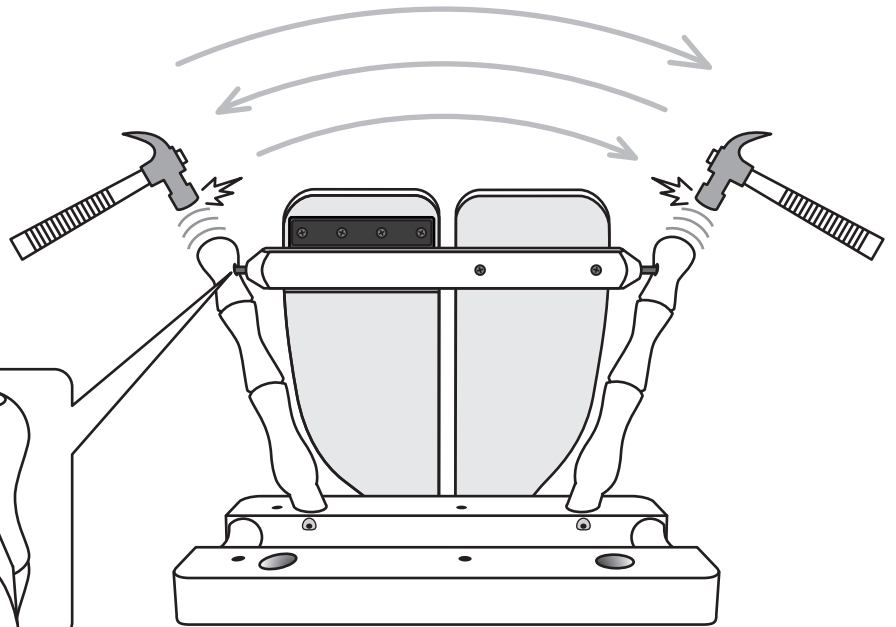

**Check!**

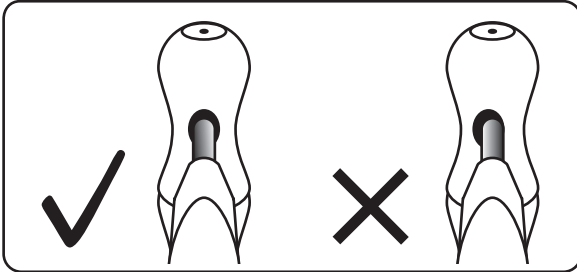

Tap the other legs to the bottom of the holes.

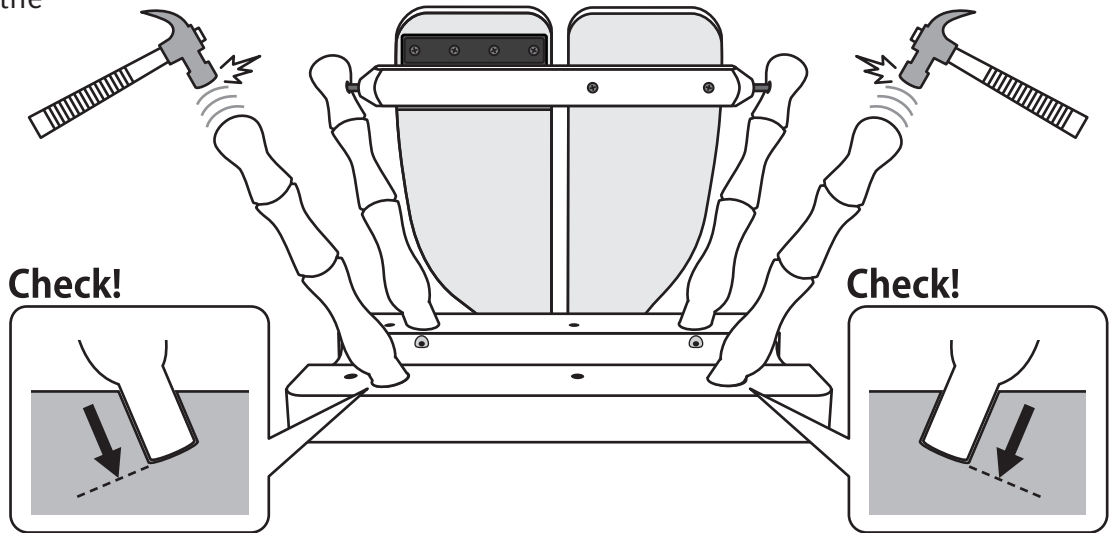

Secure the 4 legs with screws.

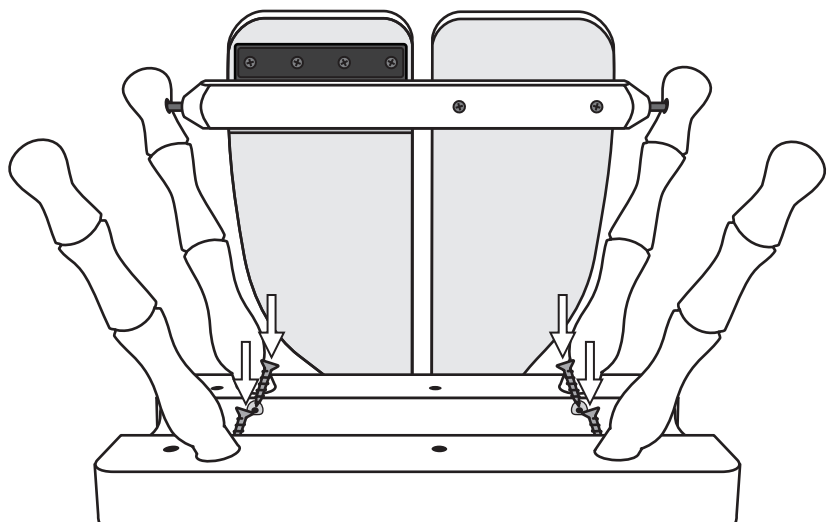

12



Turn the base and legs over. Secure the rear wheel supports with bolts and barrel nuts. This will be tightened after the next step.

**Note** the hole in one wheel support is right through. This is the rear support.

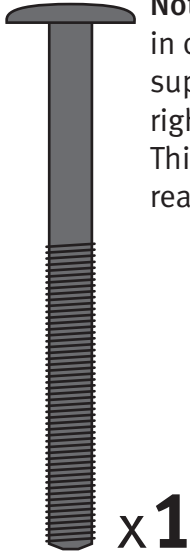

x1



x1

Check!

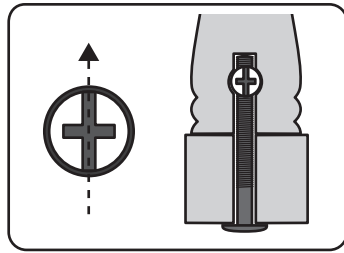

Check!

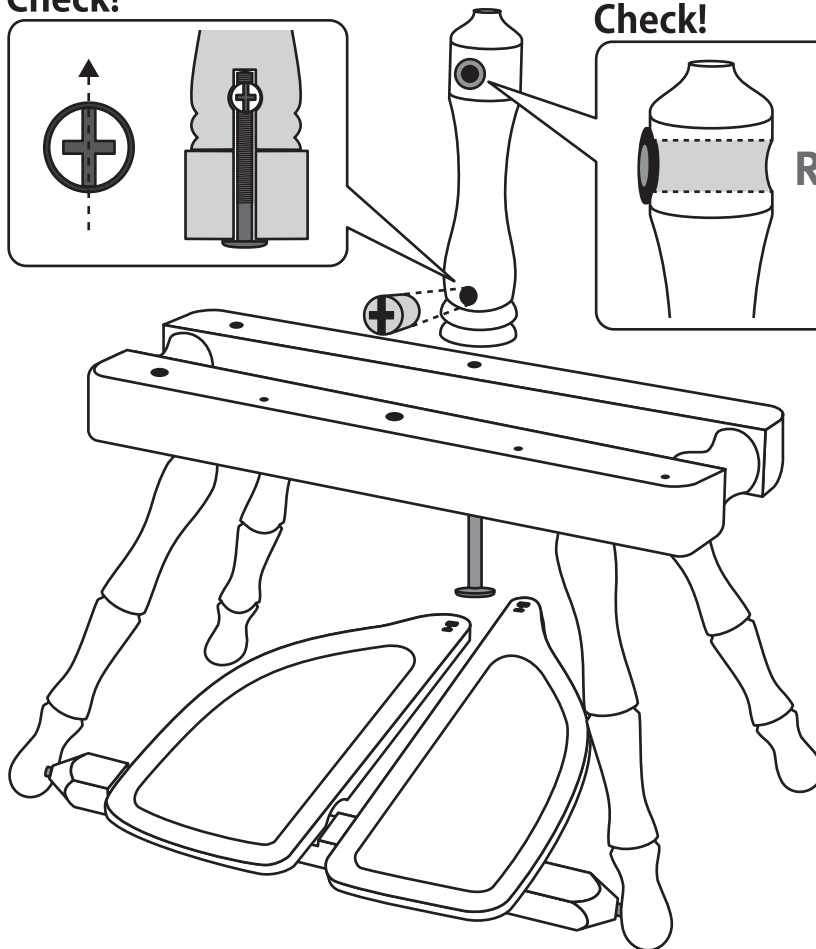
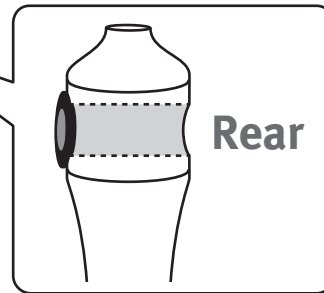

13



Secure the front wheel supports with bolts and barrel nuts. This will be tightened after the next step.

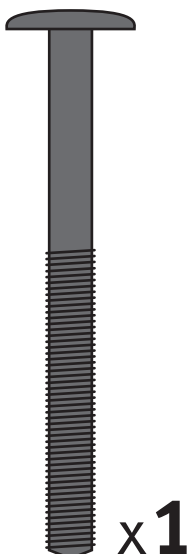

x1



x1

Check!

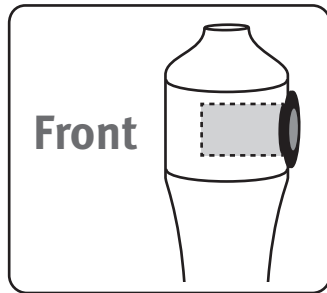

Check!

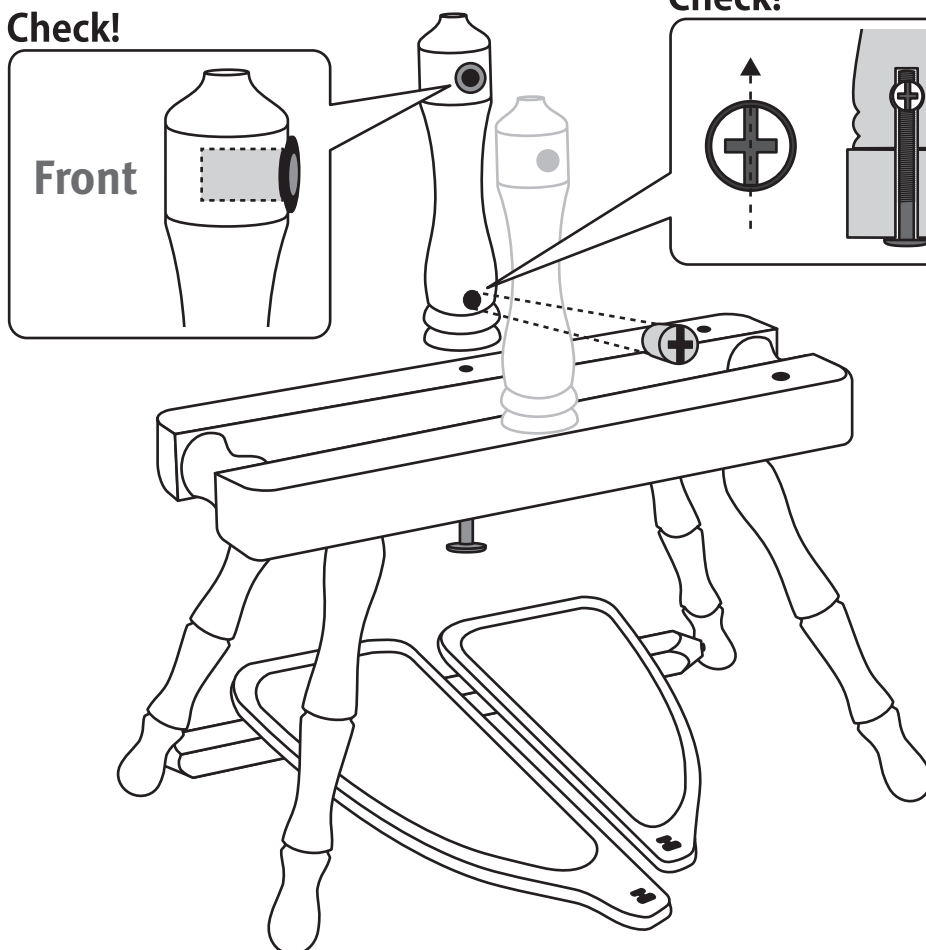
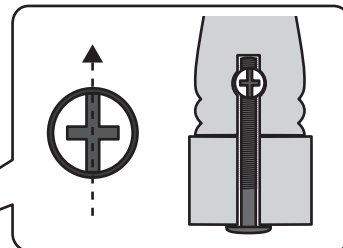



14



Check the alignment of the holes for the crank. Tighten the bolts from underneath.

Check!

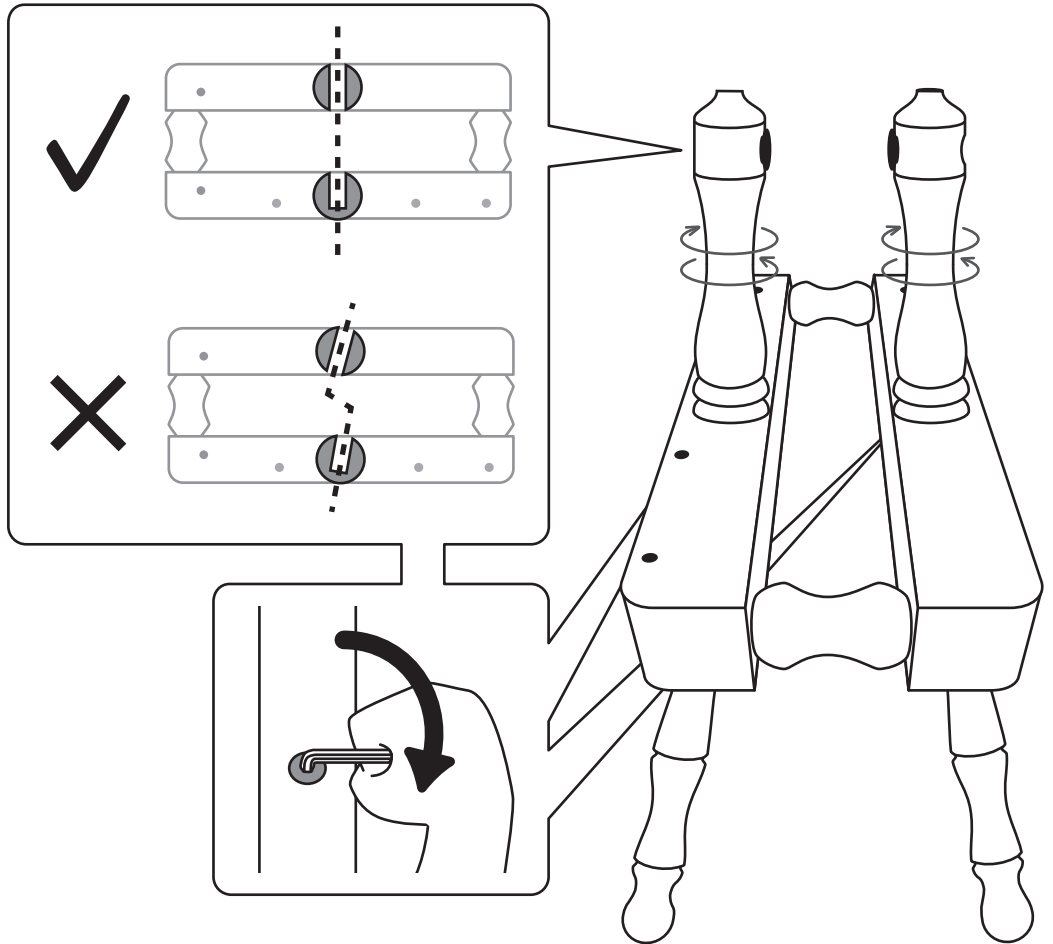

15



Place the wheel in position and insert the crank shaft. Align the hole in the crank shaft with the groove of the hub. Check the wheel is parallel in the centre of the base and the wheel supports are tight against the hub. If not, loosen the bolts, adjust the wheel supports and retighten.

Check!

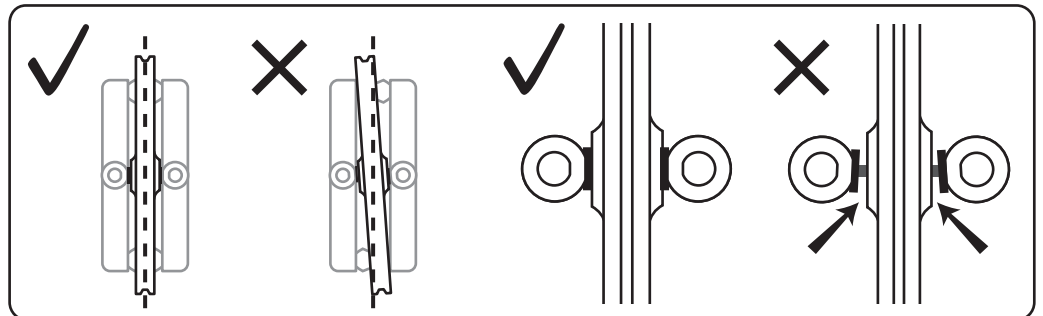

Check!

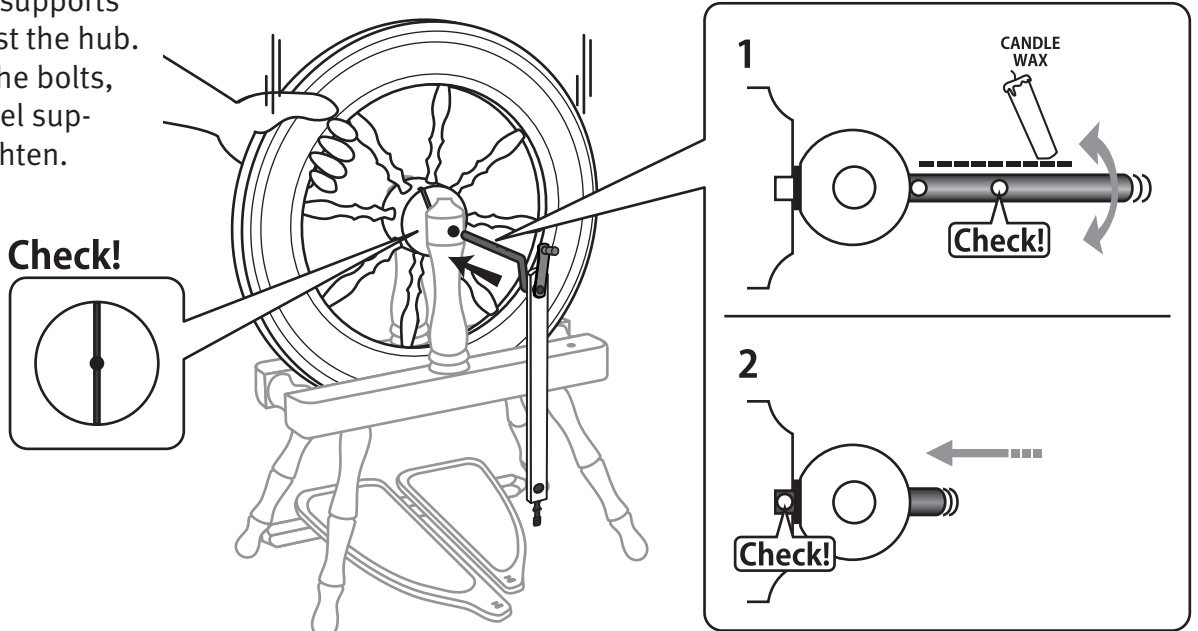

16



Rotate the hub pin until it is a firm fit in the slot in the hub. Then tap the hub pin through the hub and crank.

*Hint:* Use a Lazy Kate pin as a punch to avoid damaging the hub.

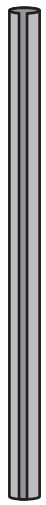

x1

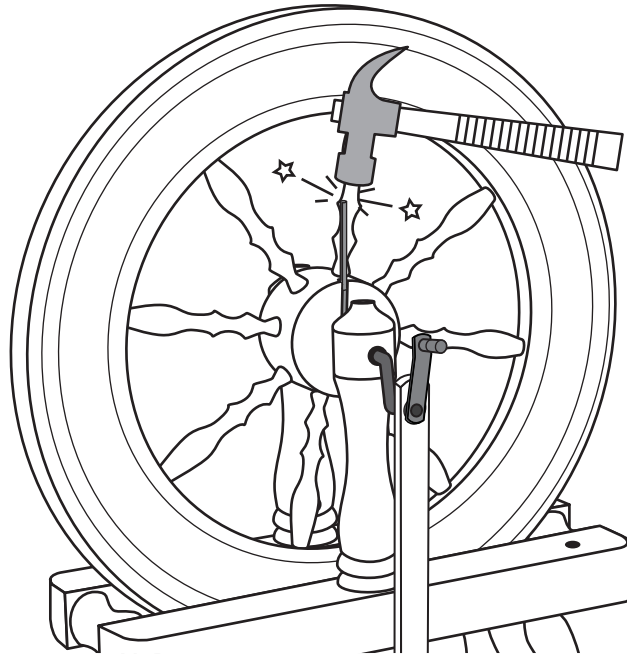

Check!

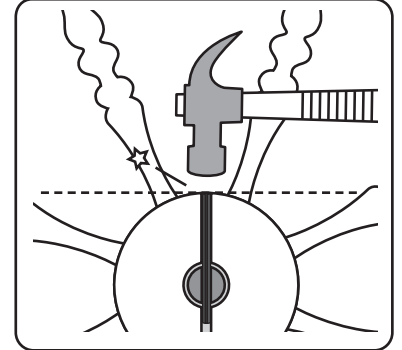

17



Slide the inner shell of the conrod universal joint onto the crank until it clicks into the groove. Then click the front conrod onto the universal joint on the crank.

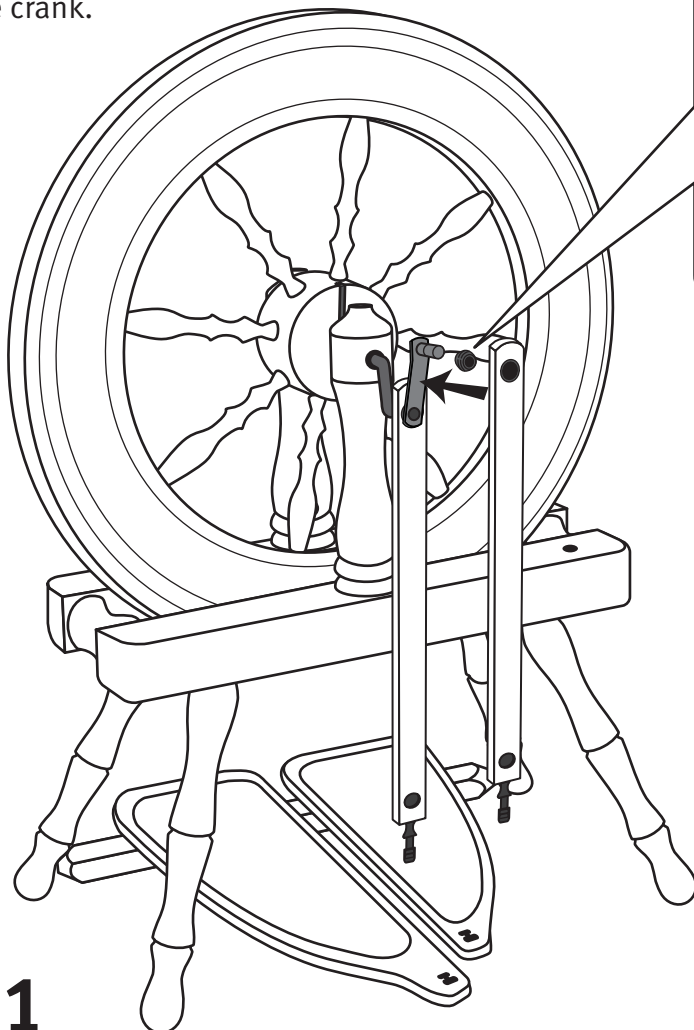

x1

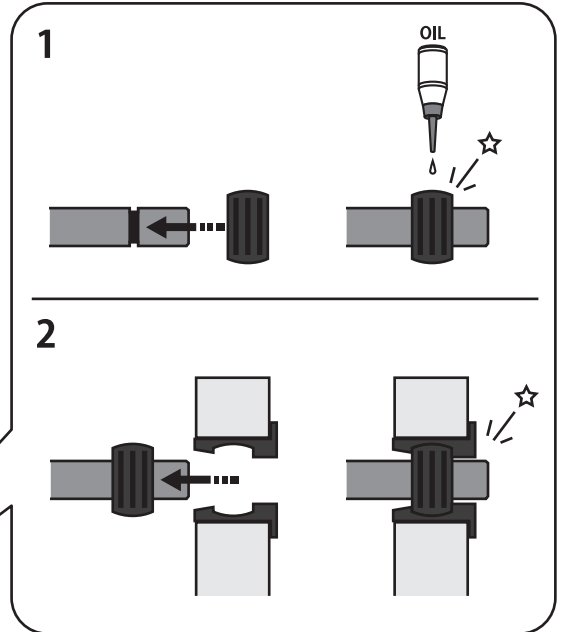

# 18

Insert the front conrod into the large slot in left hand treadle board.

1. Hold the conrod joint with one hand on either side of the treadle board.
2. With both hands, turn the conrod joint a 1/4 turn.
3. Stretch and slide it into the small slot and turn it back a 1/4 turn until it clicks into place.
4. Repeat the sequence for the rear conrod and the right treadle board.

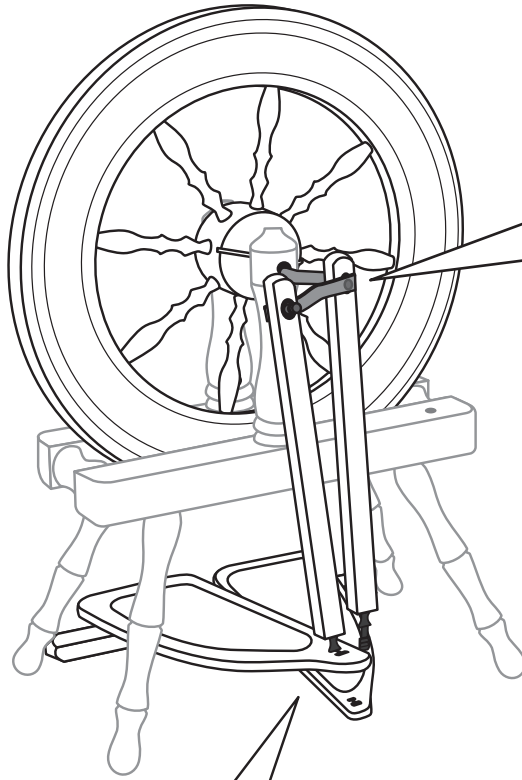

**Check!**

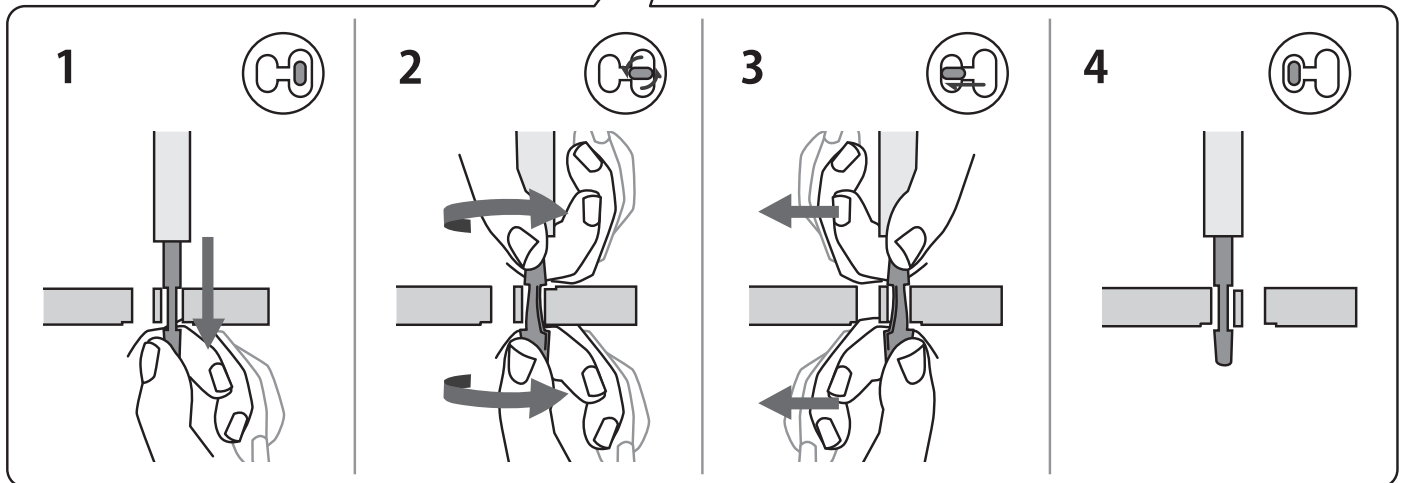
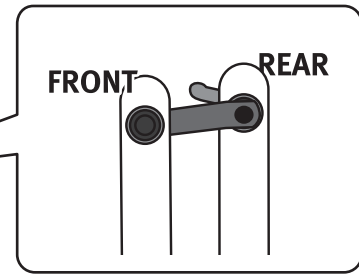

# 19



Secure the maiden bar supports with bolts and barrel nuts.

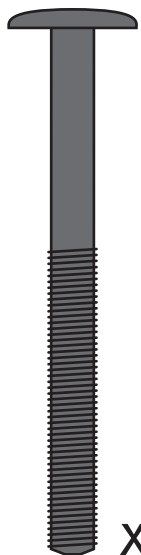

x2



x2

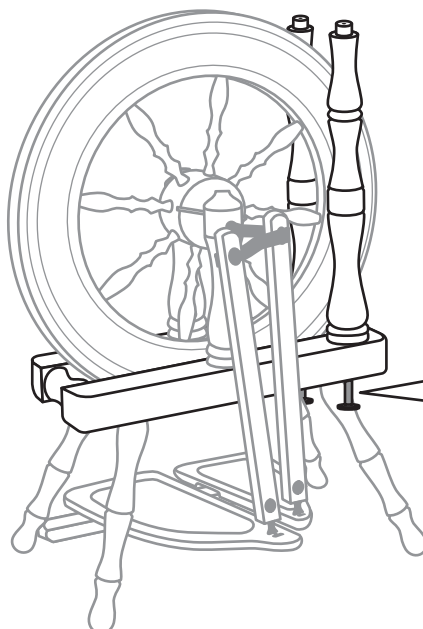

**Check!**

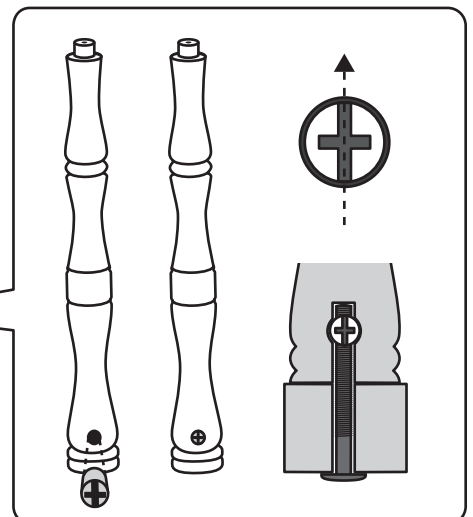

20



Secure the top rail to the maiden bar supports with 2 screws.

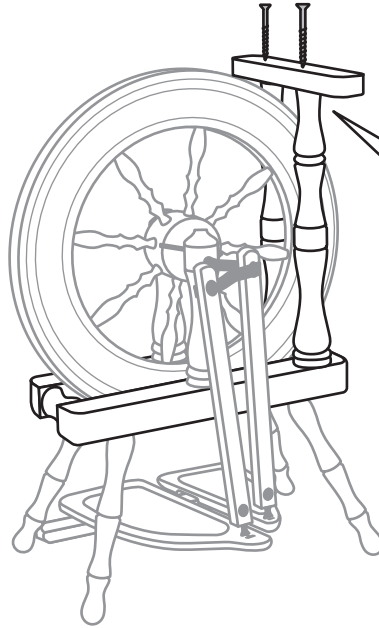
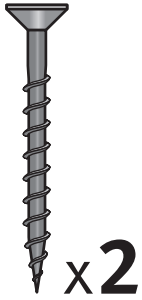

Check!

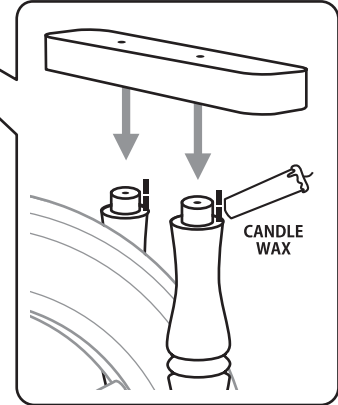

21



Secure the flyer unit to the top rail with 2 screws. These will be tightened shortly. Move the flyer unit until the wheel and middle flyer pulley are aligned. Then tighten the screws and position the drawing pin directly beneath the

drive band adjusting knob to prevent it marking the wood.

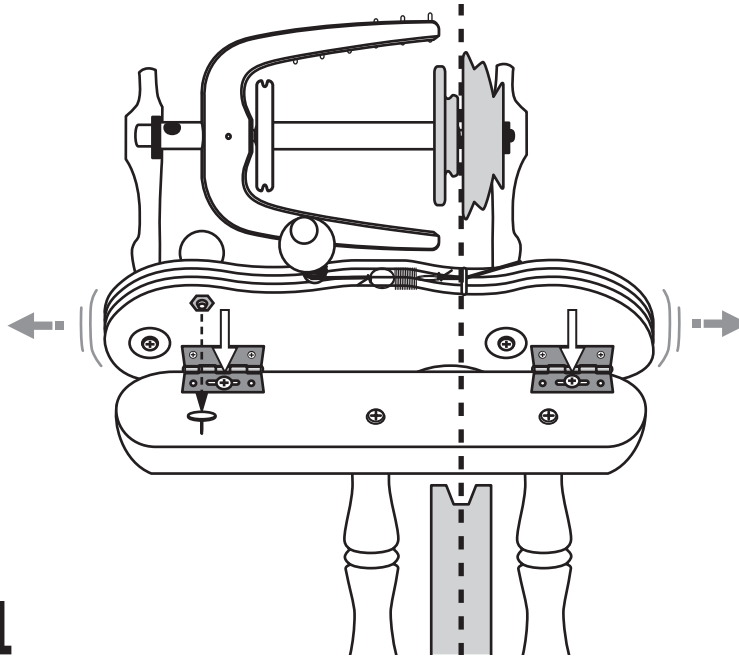

Check!

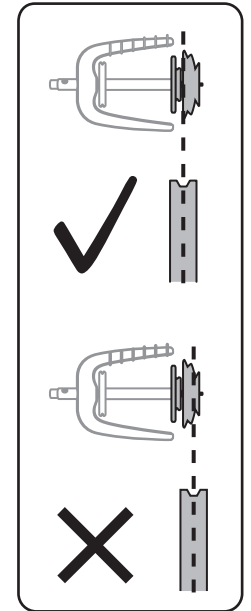

22

Tie the threading hook to the front maid upright with tape.

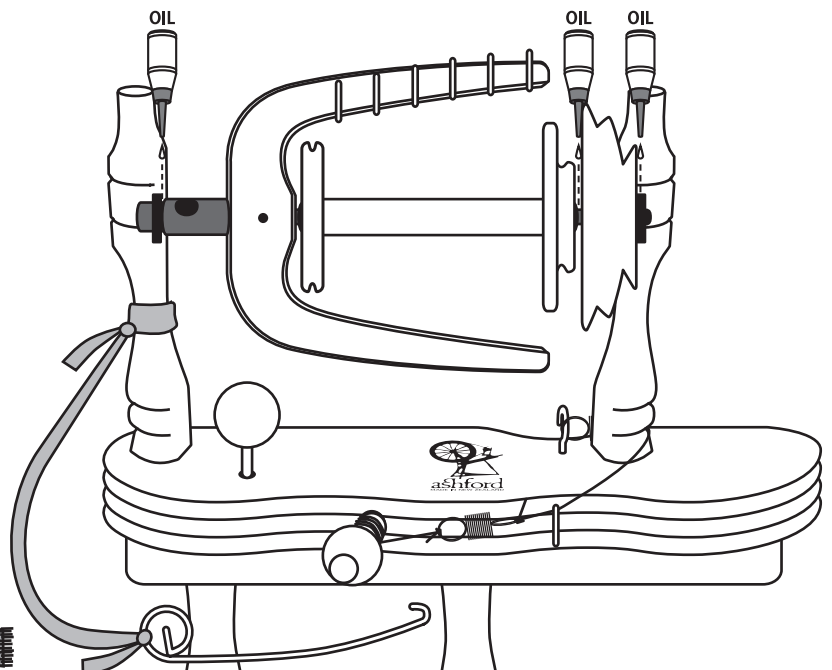
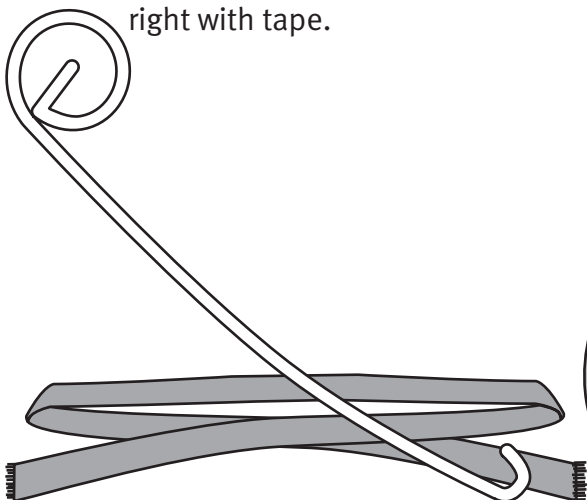

23



Check the end of the adjusting knob is not protruding beneath the maiden bar. Then wrap the drive belt around the wheel, around the large flyer pulley, back around the wheel and around the small bobbin pulley.

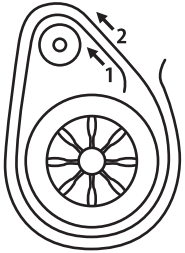

Tie drive belt and cut off the extra.



Tap the steel lazy kate pins into the base.

Check!

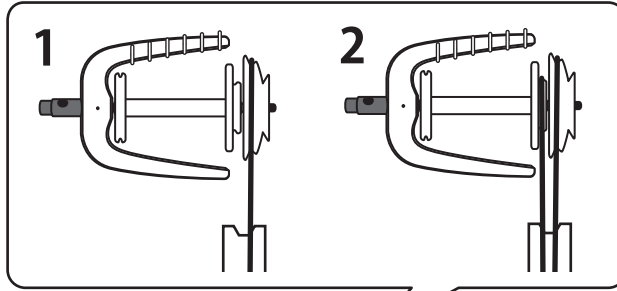

Check!

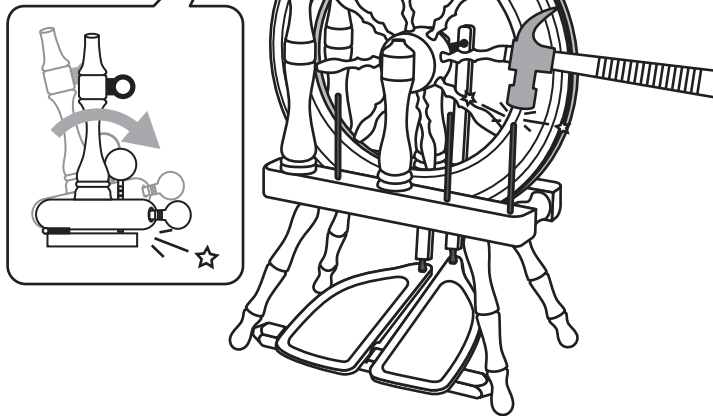

Check!

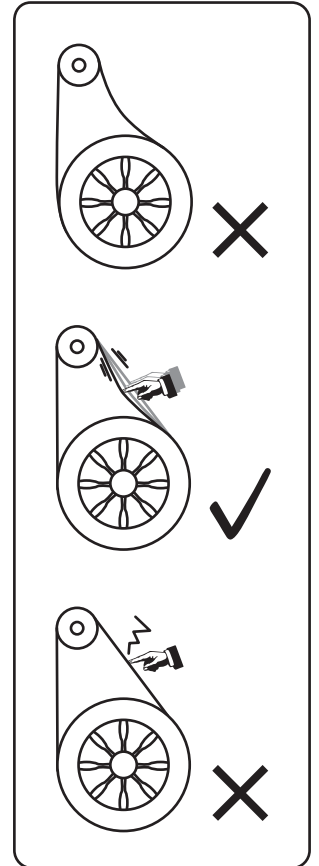

24

Ratios :

You may find it easier to spin a finer yarn if your flyer rotates faster. To change ratio simply move the drive belt to a smaller flyer pulley and retension the drive belt.

To achieve 14:1, wrap the brake band over the flyer pulley and the drive belt around the bobbin pulley. This is called "bobbin lead".

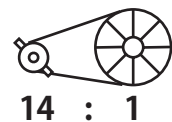
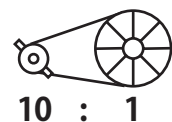
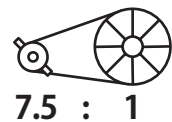
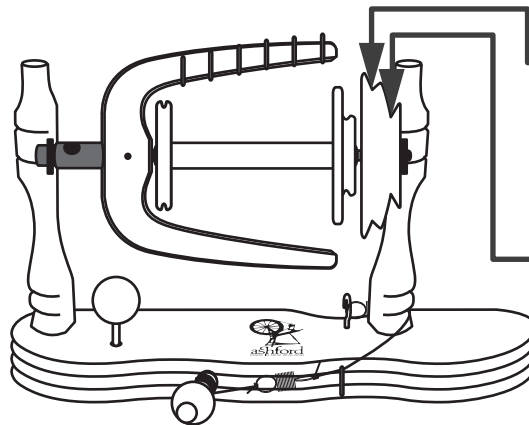

Check!

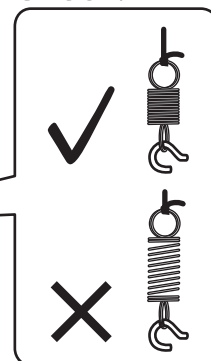
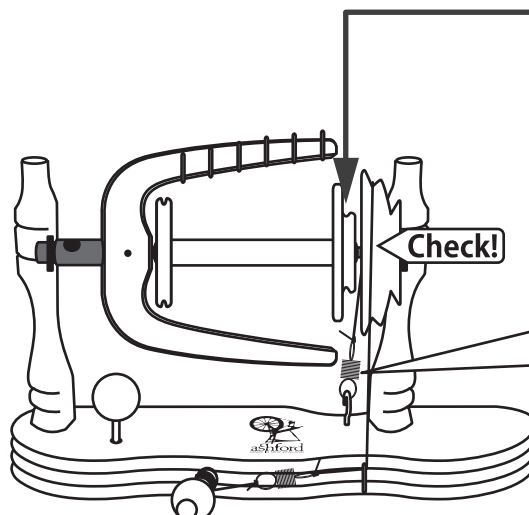

25



Oil all points on the Spinning Wheel before use as illustrated.

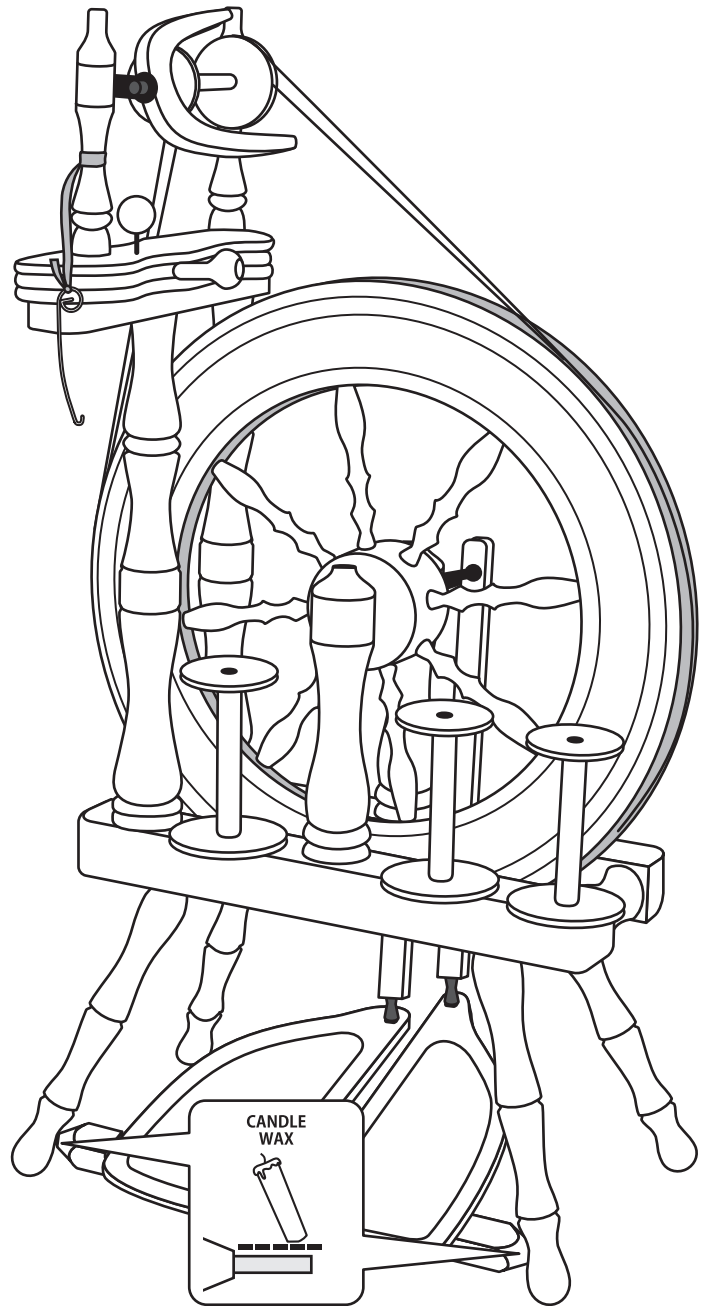
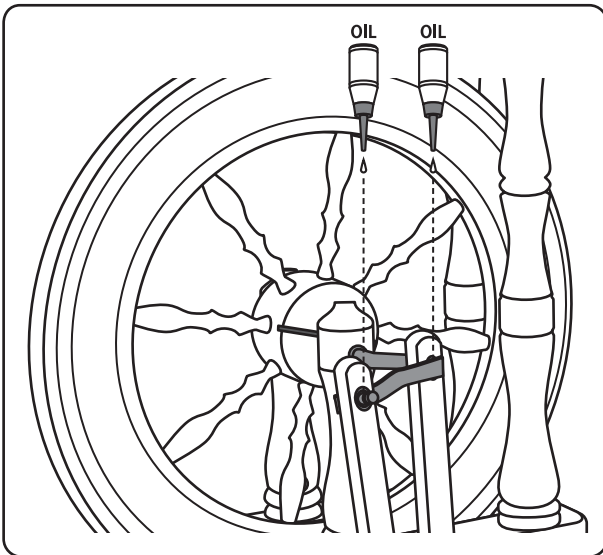
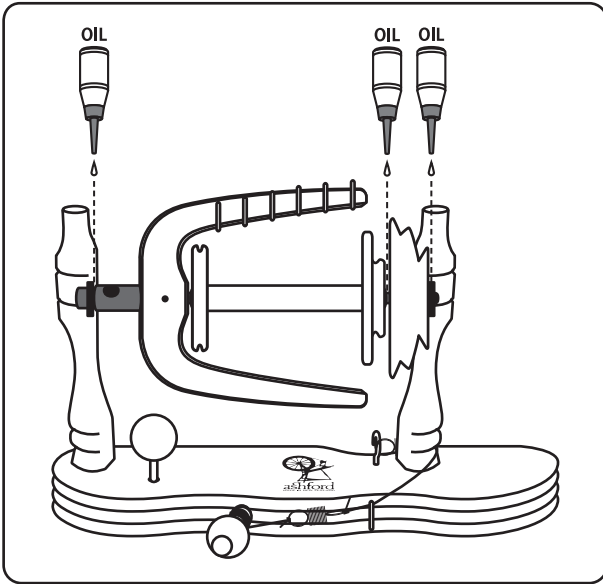

### Memo

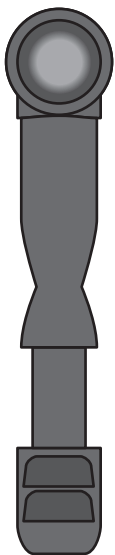

How to insert the polyurethane conrod joints into the conrod.  
\*This has been pre-assembled in the factory.

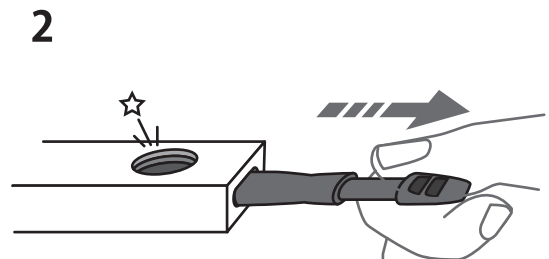
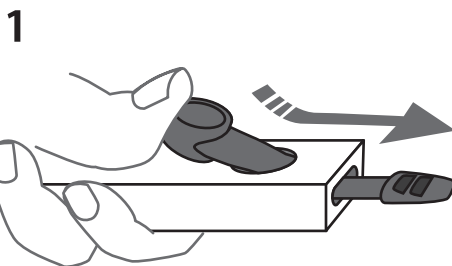

# Solutions

Does not pull yarn in

**Check!**

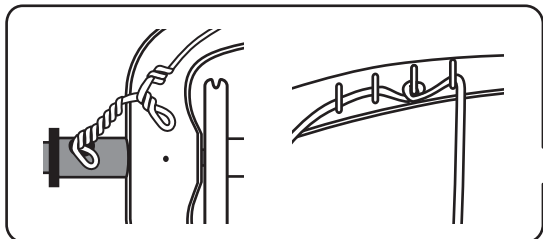

**Check!**

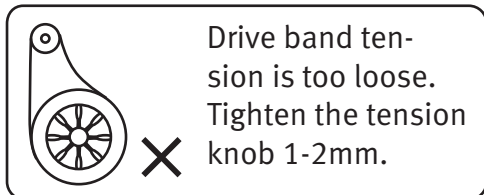

Small whorl

Large whorl

**Check!**

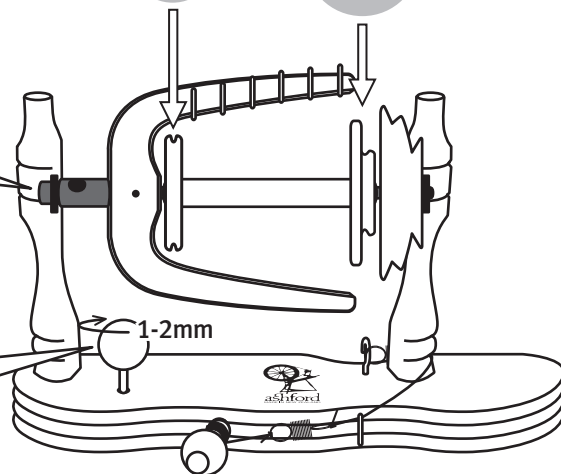

Yarn breaks

**Check!**

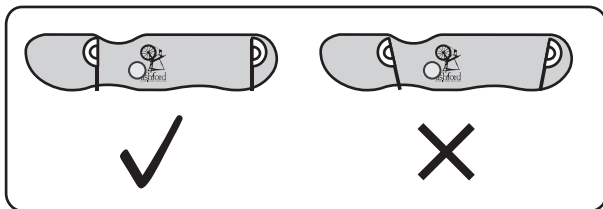

**Check!**

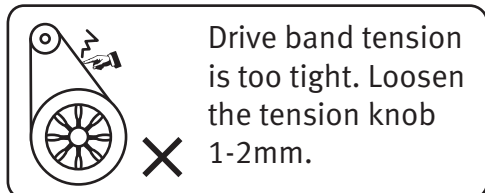

**Check!**

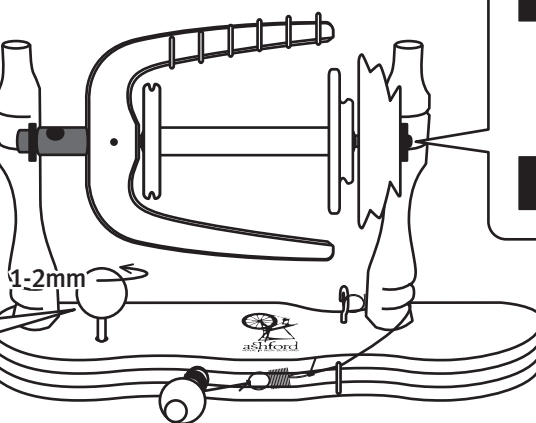
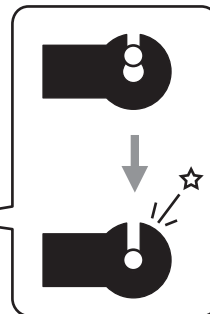

Hard to treadle

**Check!**

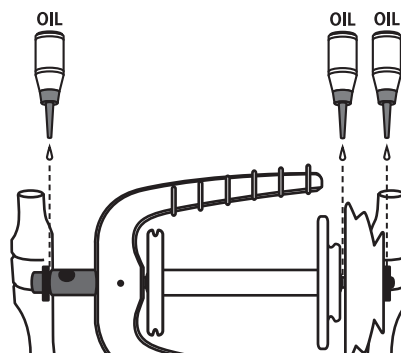
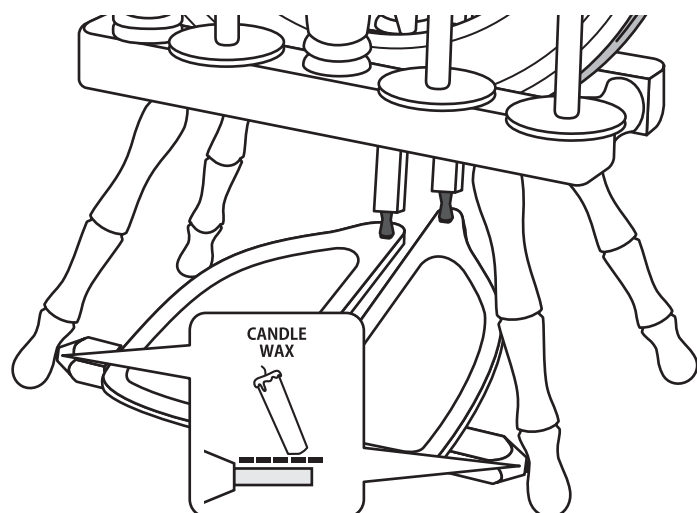
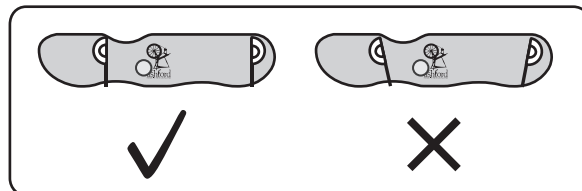

## Drive band falls off easily

Check!

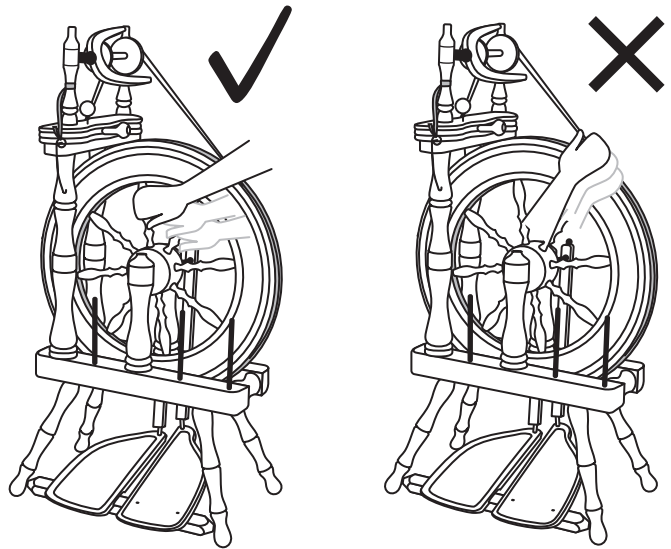
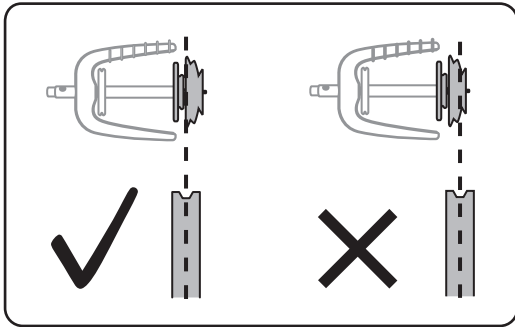

## Strange sounds

Check!

