

KIWI 2 SPINNING WHEEL

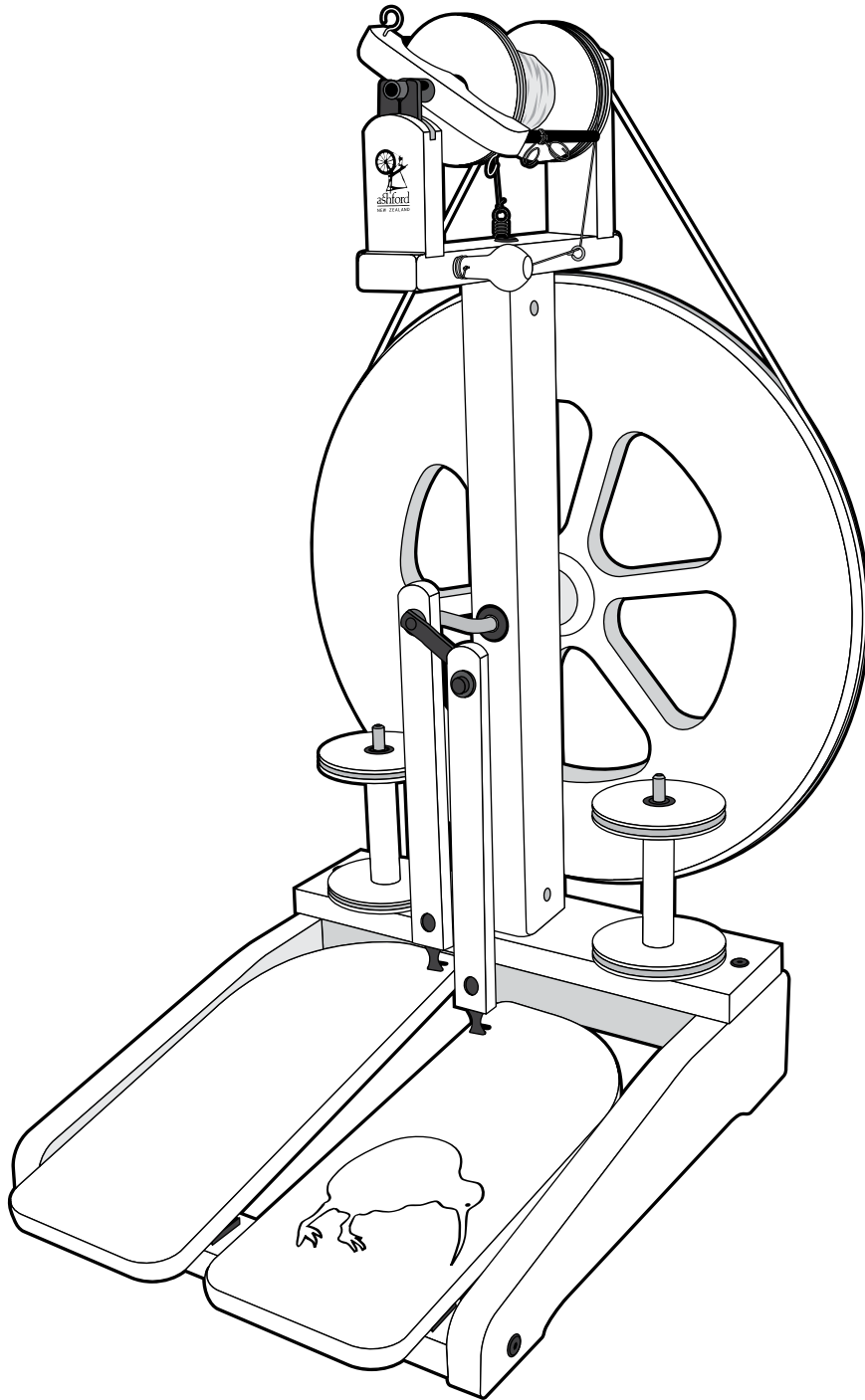

KSWII11082014V6

ASSEMBLY INSTRUCTIONS FOR THE ASHFORD KIWI 2 SPINNING WHEEL

Before commencing, please read the instructions completely, identify the parts and note the assembly sequence.

Timber

We recommend that the wood surfaces be waxed or sealed before assembly. This protects the kiln dried wood from climatic changes and prevents it getting dirty or stained. The Silver Beech tree is a native of New Zealand and has a lovely variety of colour and grain. For a silky smooth matt finish, use the Ashford Wax Finish to enhance the natural colours and character of this timber.

MDF

The Kiwi2 wheel is made from New Zealand manufactured MDF (Medium Density Fibre board). MDF is an engineered wood-based product made by bonding wood fibres with a synthetic resin adhesive. This resin has been known, in very rare cases, to cause irritation if dust is inhaled or comes in contact with the skin. We recommend wiping away any dust with a moist rag and then sealing the surfaces with a 3 coat application of polyurethane or paint.

MDF is an extremely versatile material that can be machined and finished to a high standard and has been used to make furniture for over 30 years. The Kiwi2 Spinning Wheel is also available factory finished in clear lacquer.

Tools Required



(including)

Hints

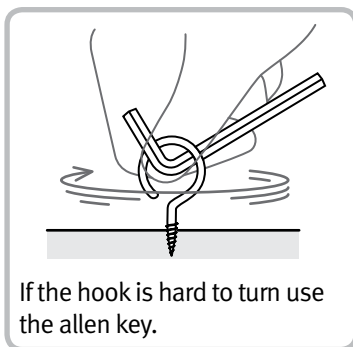
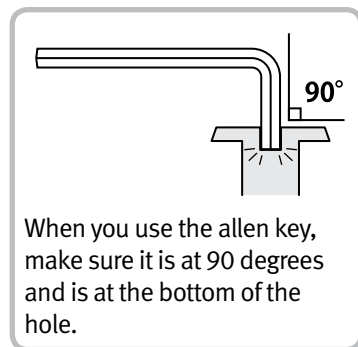
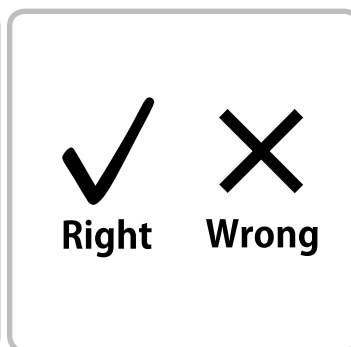
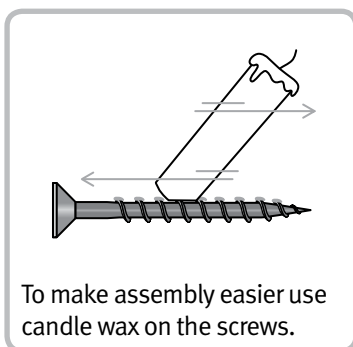
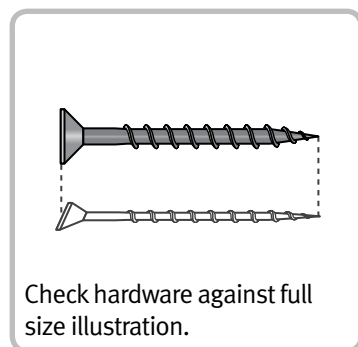

More Information



How-to videos on You Tube

Watch our how-to videos on You Tube.
www.youtube.com/user/AshfordHandicrafts



Facebook

Join us on facebook.
www.facebook.com/ashford.wheels.looms

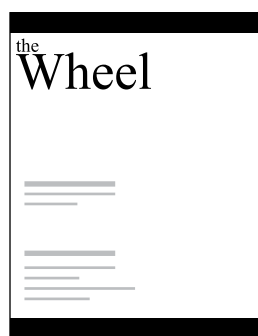

The Wheel Magazine

Ashford's annual fibrecraft magazine. Spinning, weaving, felting, dyeing and knitting projects, patterns and articles from around the world. To receive the glossy version delivered to you, subscribe at:
www.ashford.co.nz/subscribe

Real Scale Hardware List

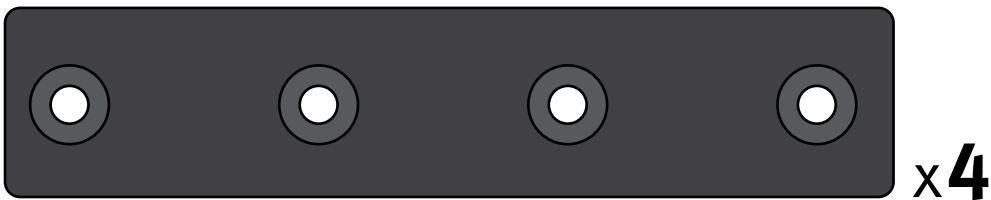
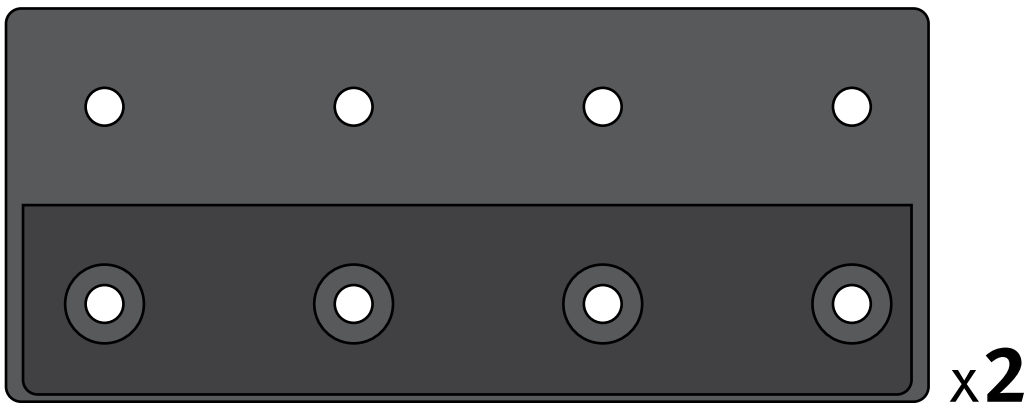
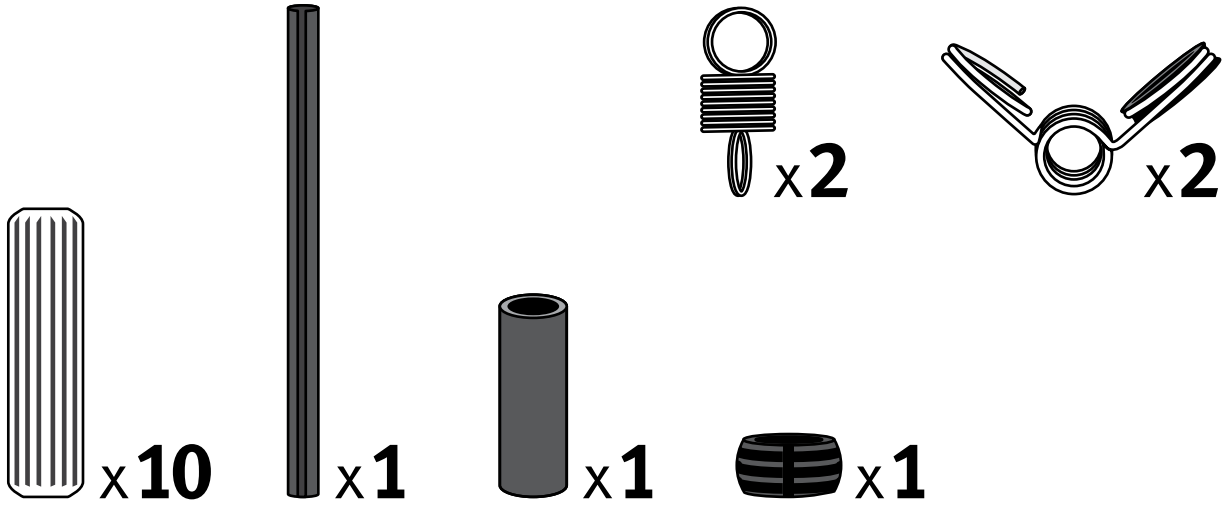
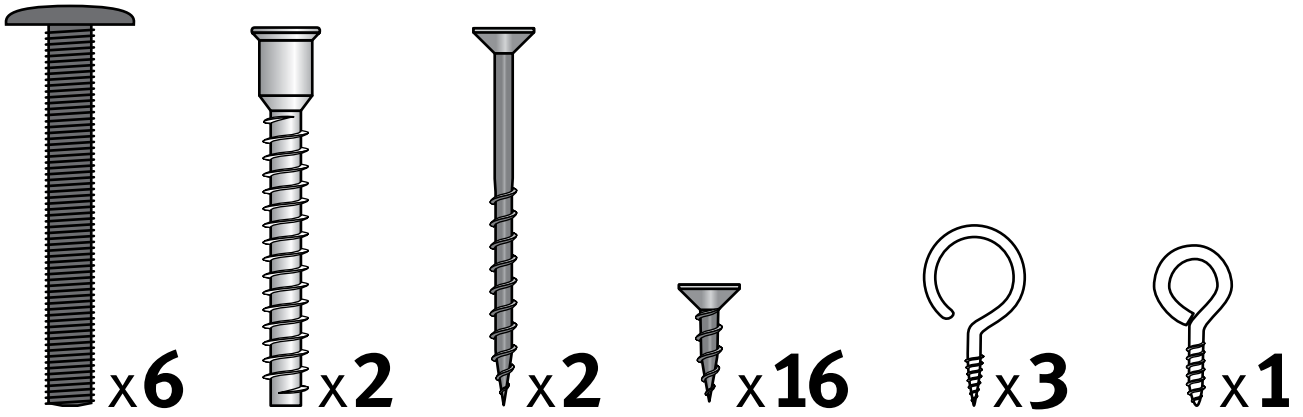

Metal Plate

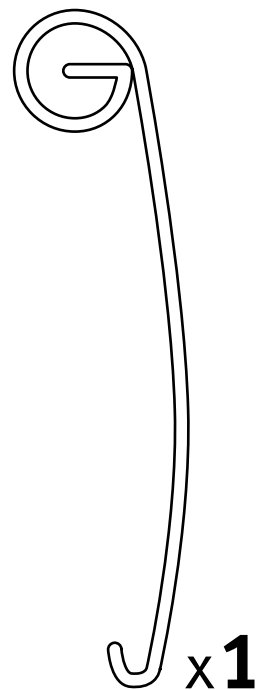



Thread 2 hooks into the flyer base. Squeeze and slide the yarn guides onto the flyer arms.

Apply a drop of oil to the flyer shaft and slide the bobbin and flyer whorl into position.

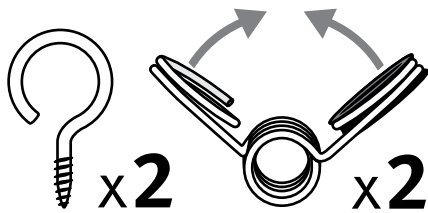

Check!

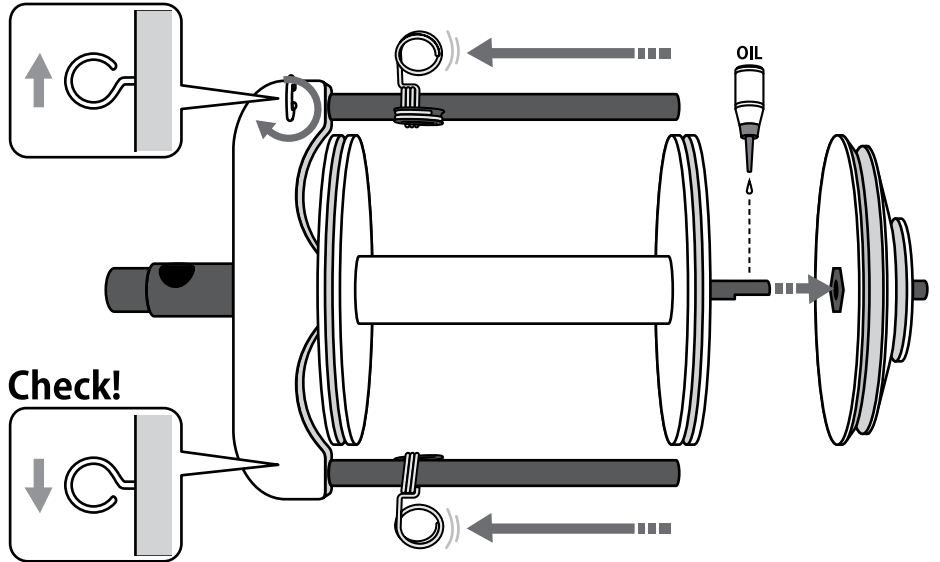

Tap wooden dowels to the bottom of the holes in either end of the treadle rail.



Check!

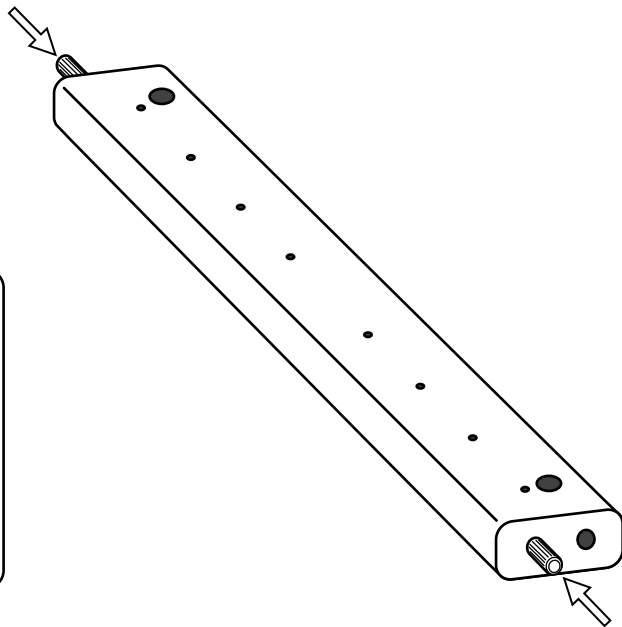
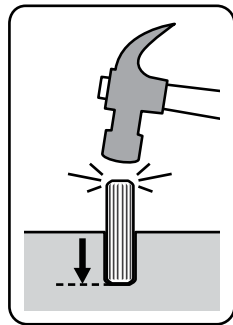

Loosely attach the feet to the treadle rail with 50mm (2") bolts and barrel nuts. Sit the base on a flat surface and check the feet are level. Then tighten the bolts.

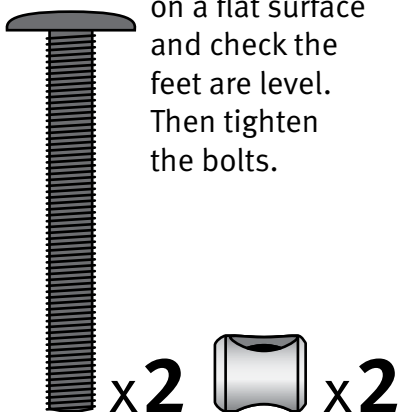

Check!

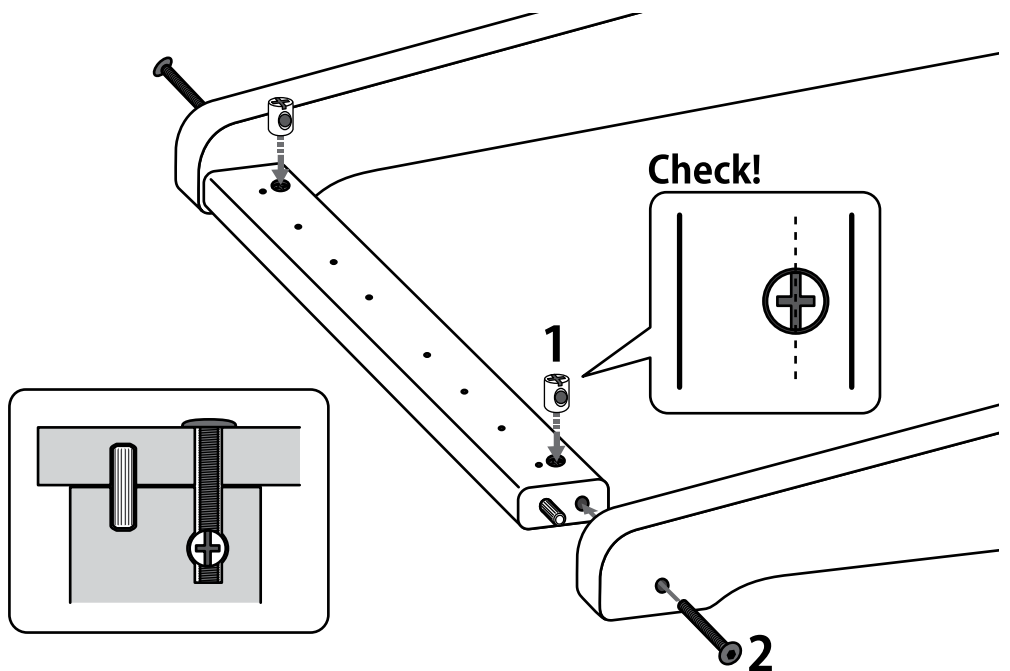



Locate the metal cover plates into the polyurethane hinges. Then attach the hinges to the treadle rail with 16mm (5/8") screws.

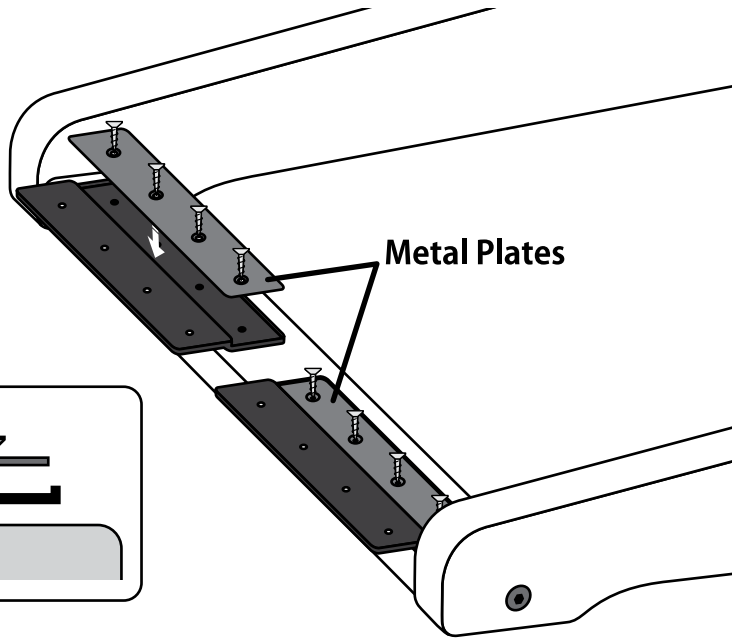

Lay the base on its back. Locate the metal cover plates into the polyurethane hinges. Then attach the treadle boards to the hinges with 16mm (5/8") screws.

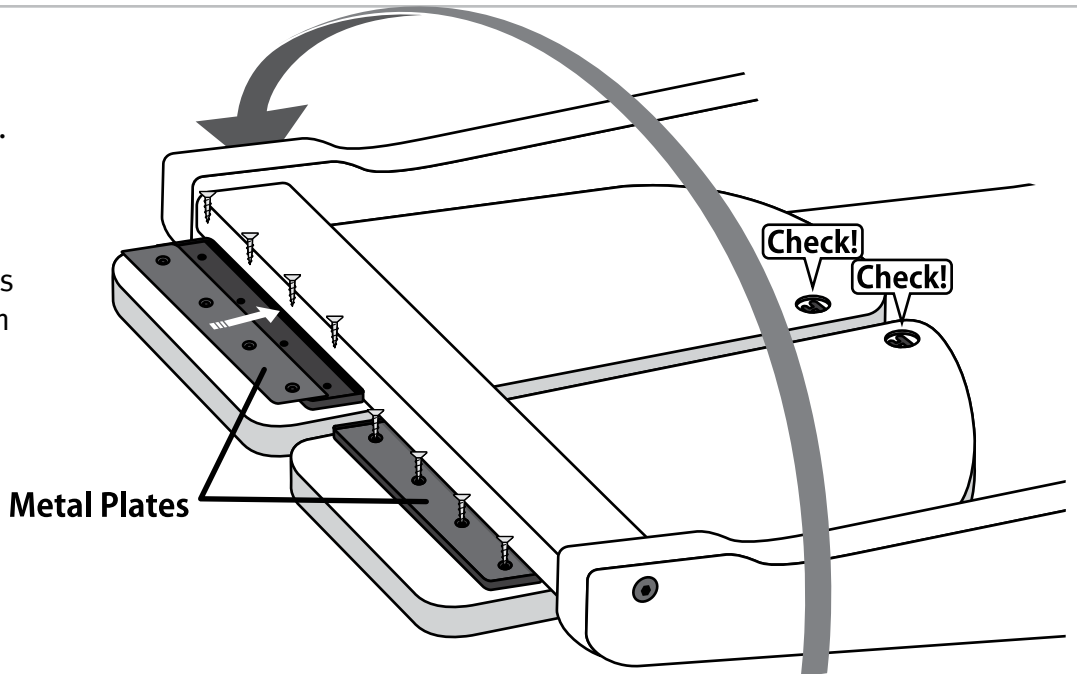

Turn the base back over. Tap wooden dowels down to the bottom of the holes in the feet.

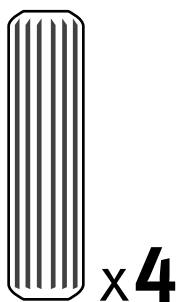
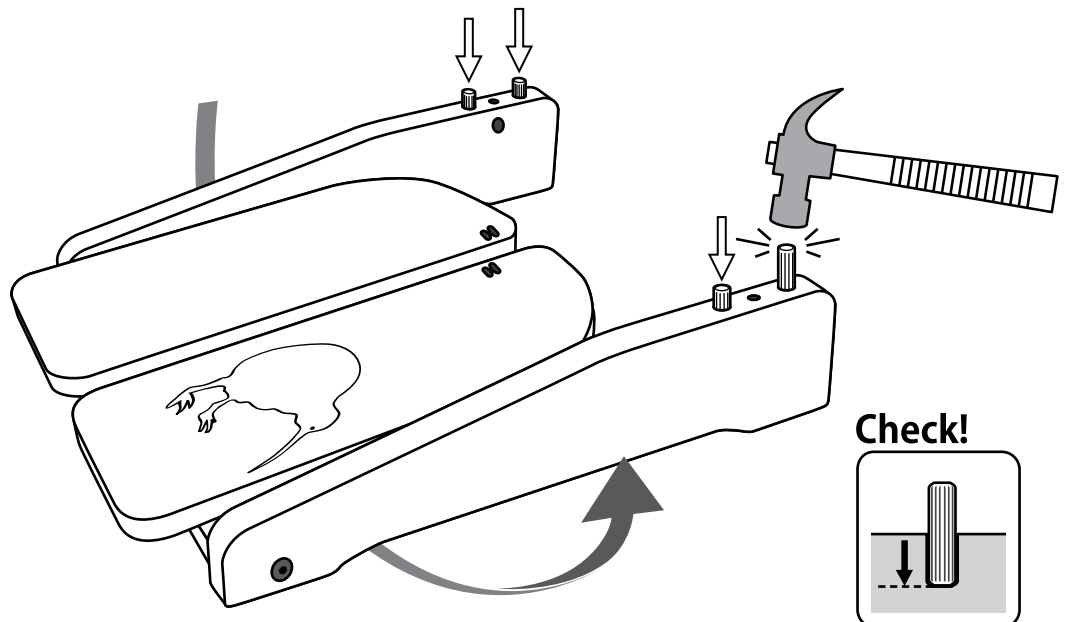

7



Attach the "toe saver" to the base with 50mm (2") screws.

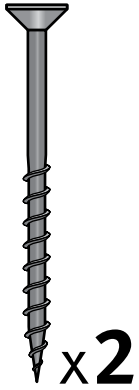

x2

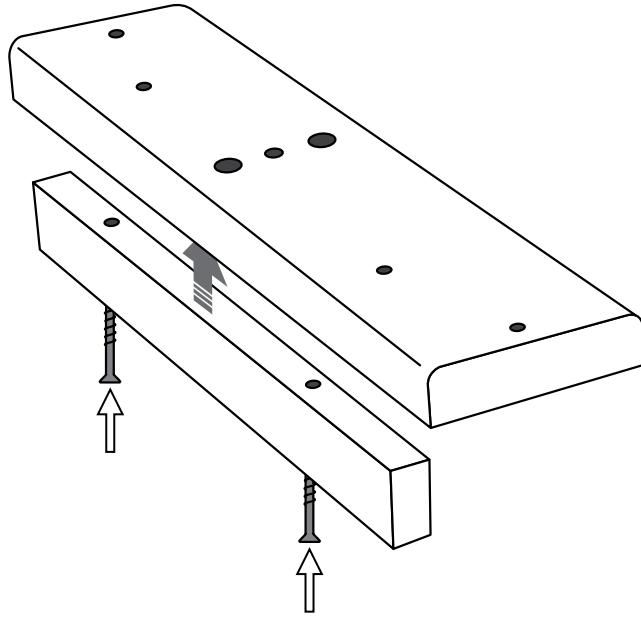

8



Locate the base onto the dowels and secure the base to the legs with 50mm (2") bolt and barrel nuts. Note the "toe saver" is towards the front.

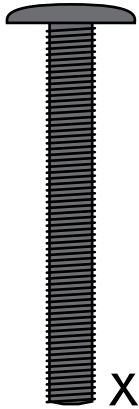

x2

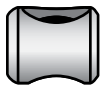

x2

Check!

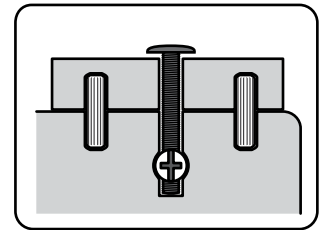
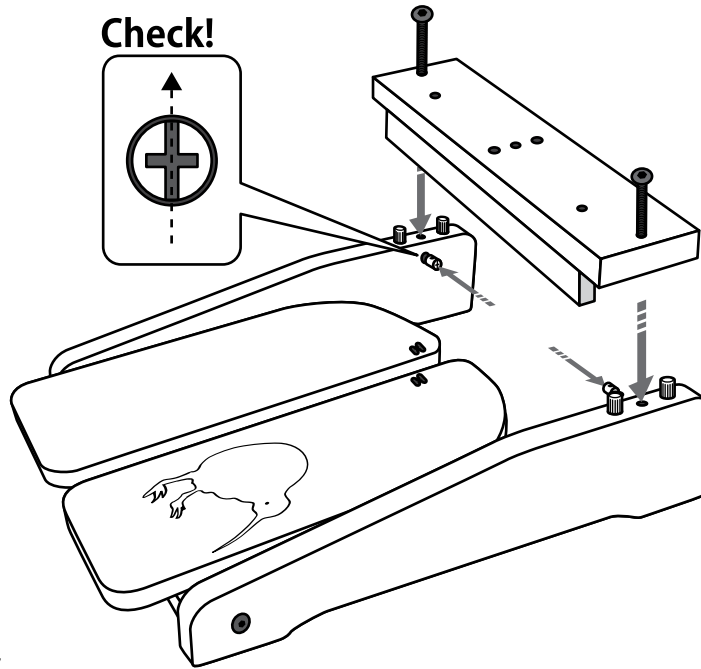
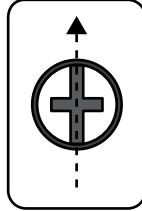

9



Tap wooden dowels to the bottom of the holes in both ends of the main upright.

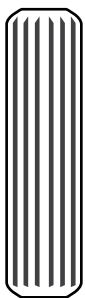

x4

Check!

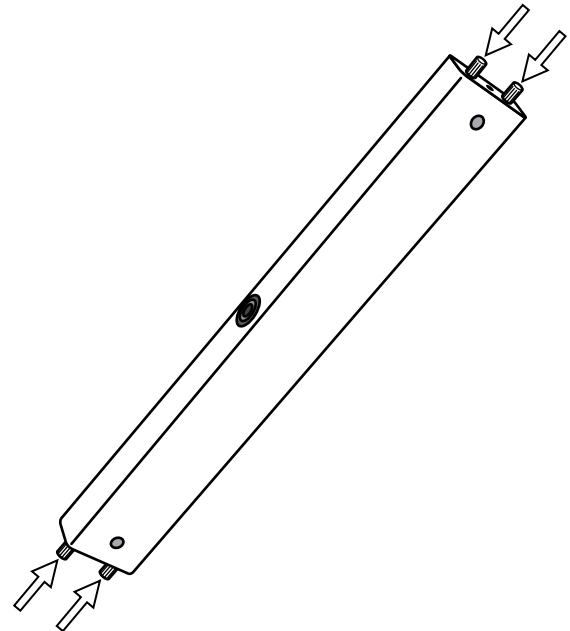
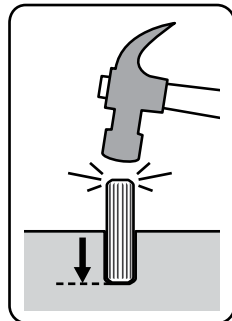

10

Position the main upright onto the holes in the base. Check that the ball bearing with the extension faces the back. Secure main upright in place with a 50mm (2") bolt and barrel nut.

Check!

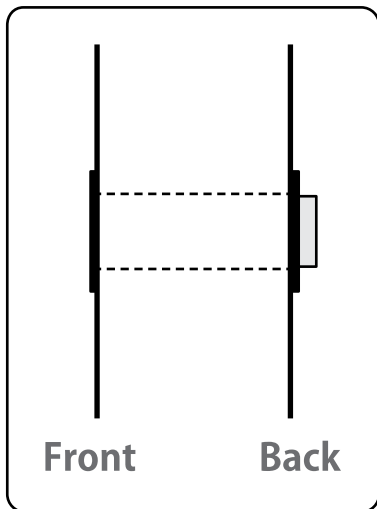

Check!

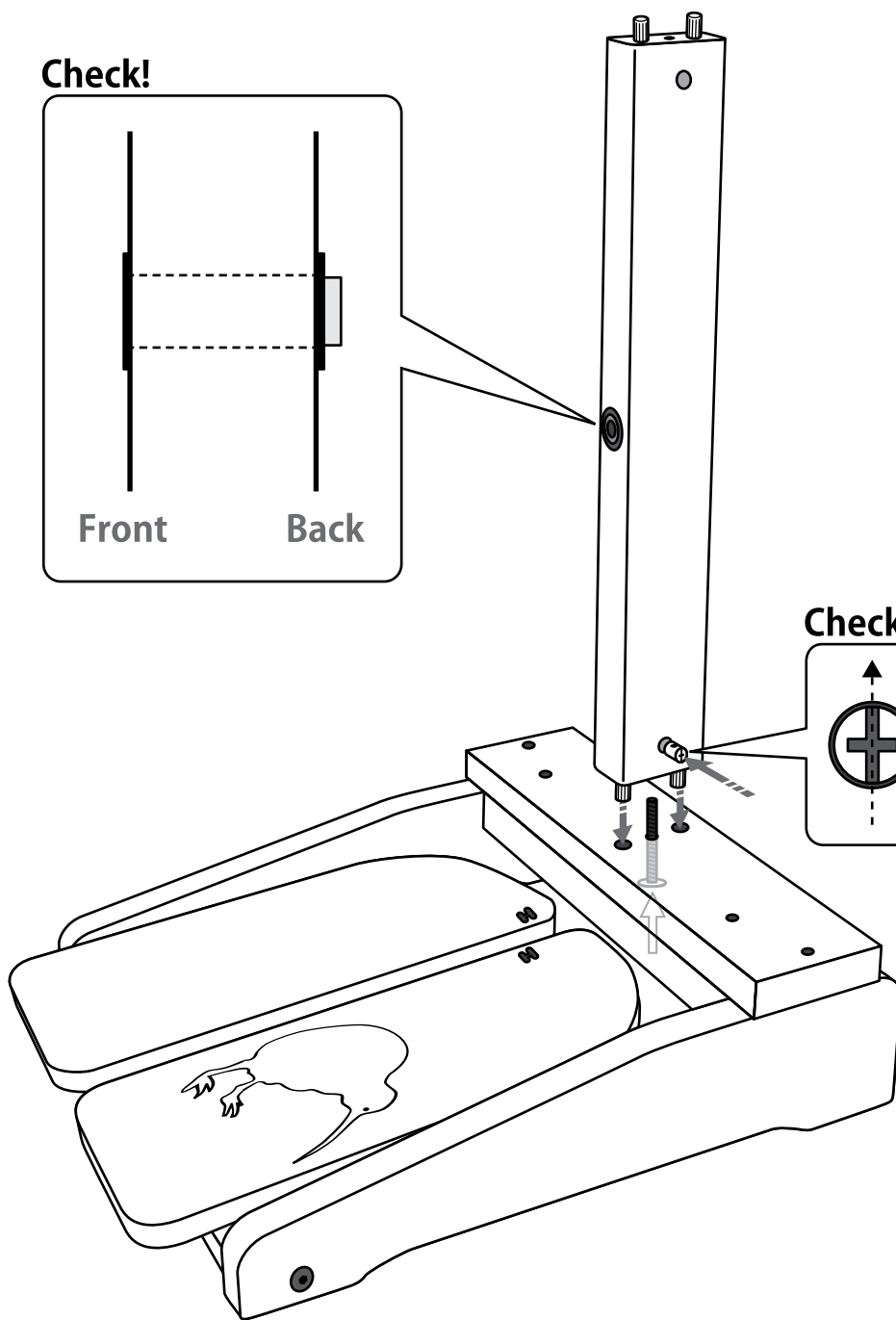
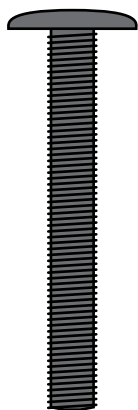
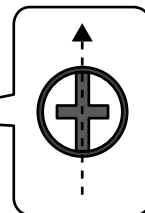

11



Slide the crank through the ball bearings.

Check!

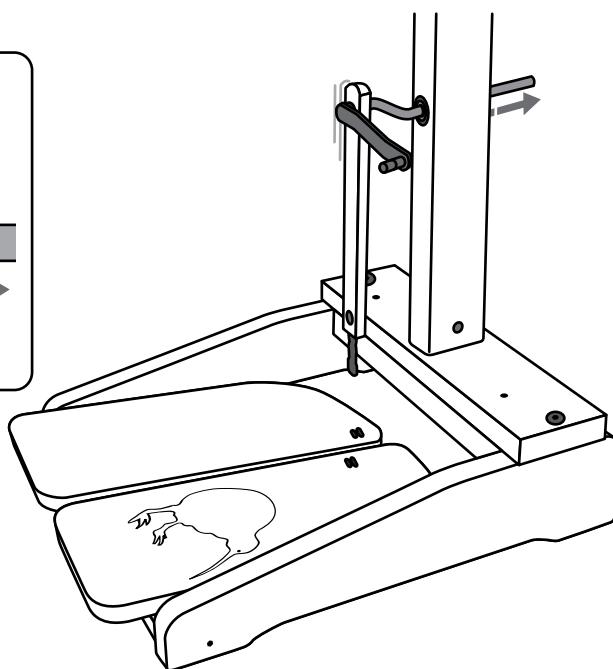
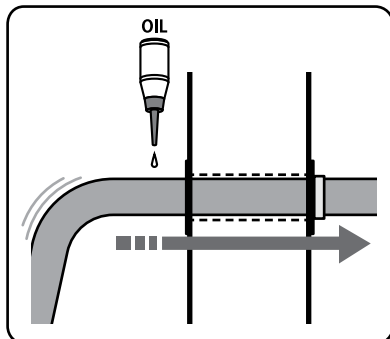

12

Slide the inner shell of the conrod universal joint onto the crank until it clicks into the groove. Then click the front conrod onto the universal joint on the crank.

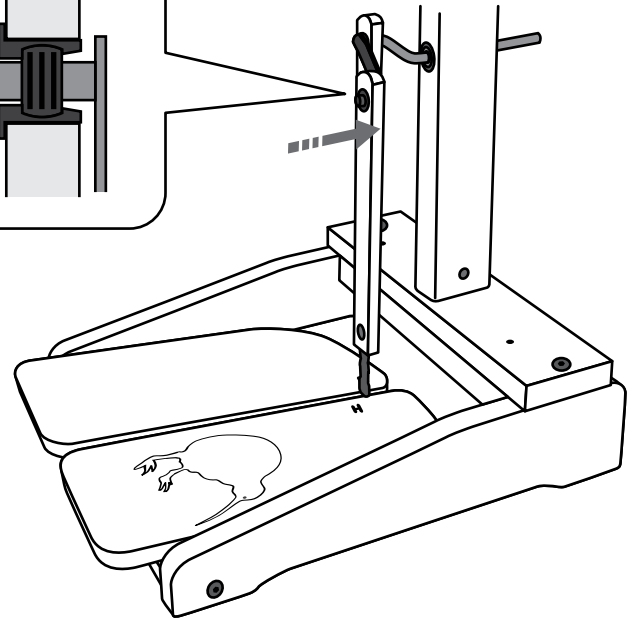
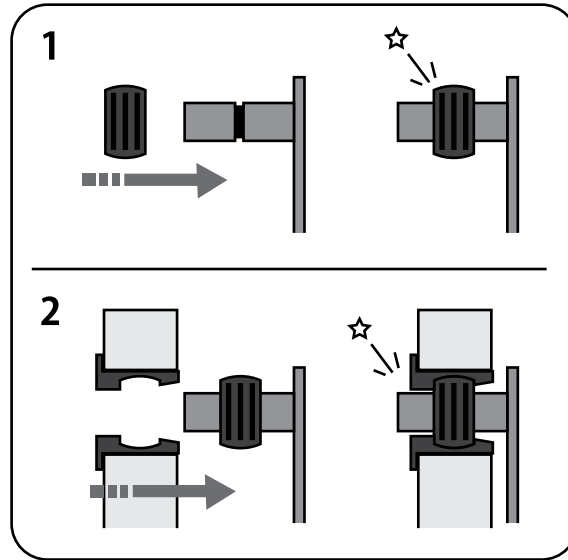

13

Place the wheel in position.

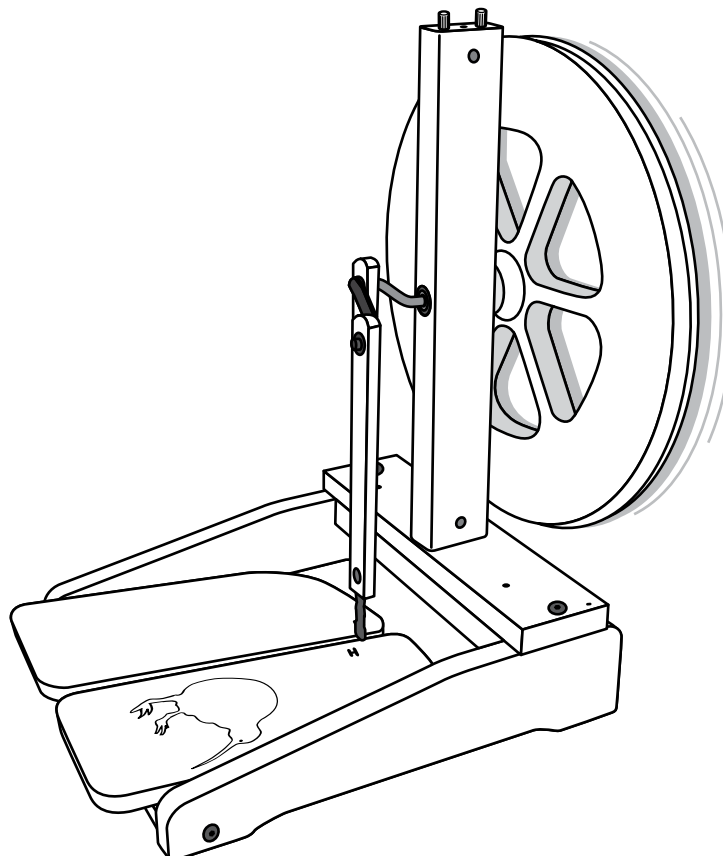

Check!

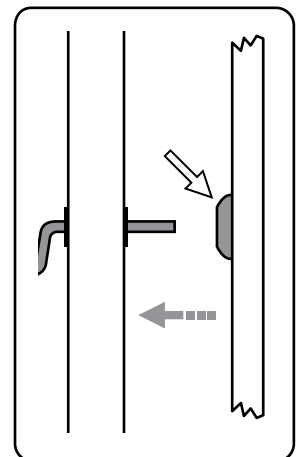

14



Align the wheel and hole in the crank shaft with the groove in the hub.

Carefully tap the hub pin through the hub and crank.



Check!

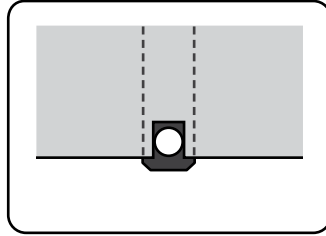

Check!

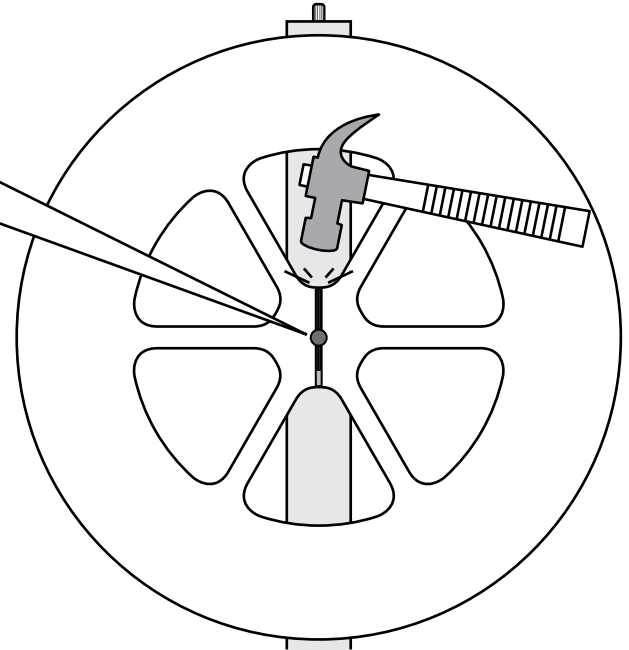
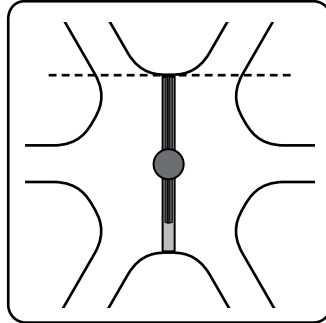

15

Lay the wheel on it's back. (protect your table with a towel or piece of cardboard)

Remove the *front* conrod from the crank.

Insert the *front* conrod joint into the *right* treadle board.

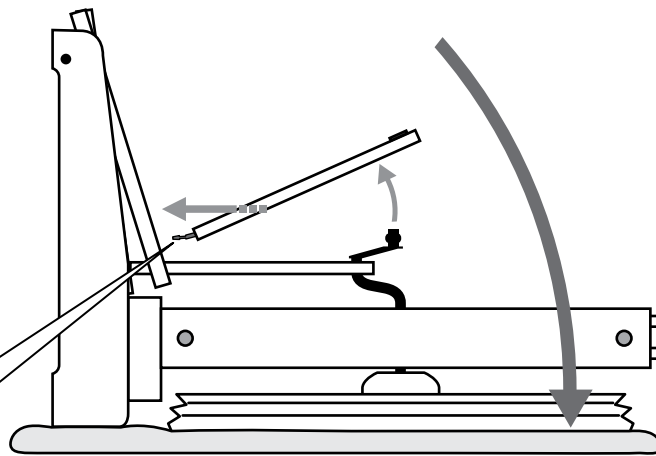

Check!

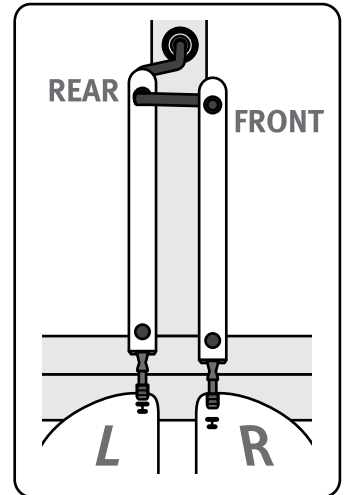

Note that the rear conrod attaches to the left treadle board and the front conrod attaches to the right treadle board.

1 Hold the conrod joint with one hand on either side of the treadle board.

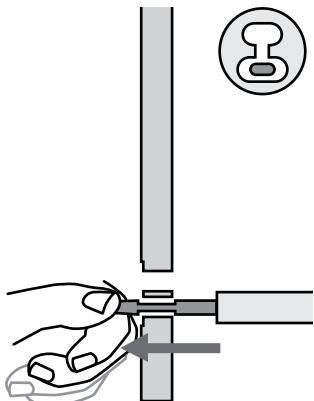

2 With both hands turn the conrod joint a 1/4 turn towards you.

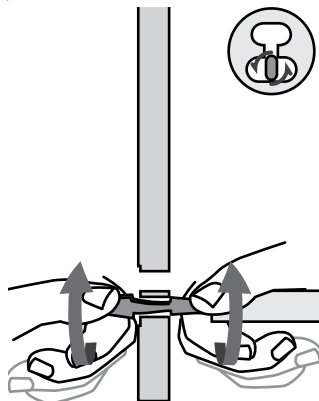

3 Slide it up into the small slot and turn it back a 1/4 turn until it clicks into place.

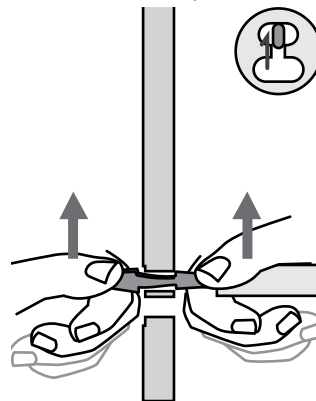

4

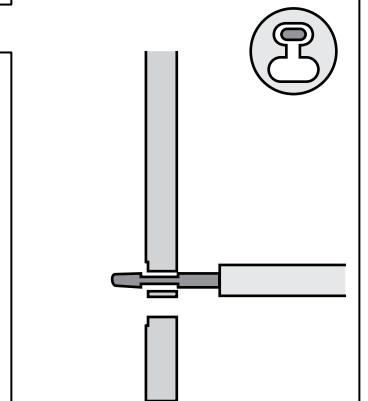

16

Then repeat this sequence for the **rear** conrod and the **left** treadle board.

Finally click the front conrod back onto the crank.

NOTE: It easier to insert the rear conrod joint into the treadle board when the treadle board is at the lowest point - turn the wheel until the rear conrod is in the lowest position.

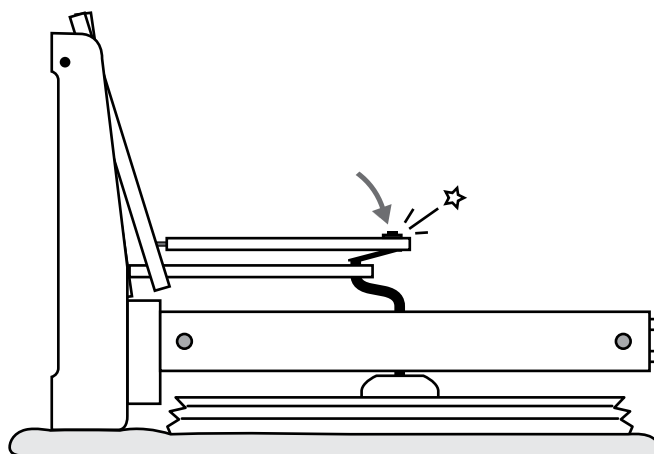

17



Tap the nylon bearing down to the bottom of the hole in the rear flyer support.

Check!

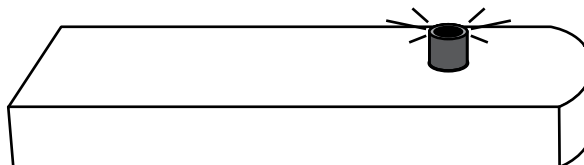
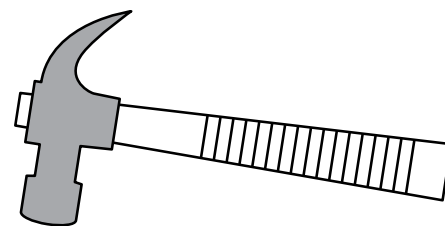
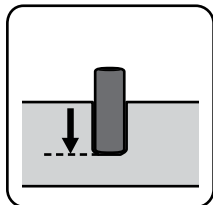

18



Secure the front and back flyer supports to the maiden bar with 50mm (2") Allen head screws.

Screw the hook and eye into the maiden bar.

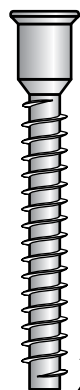

x2

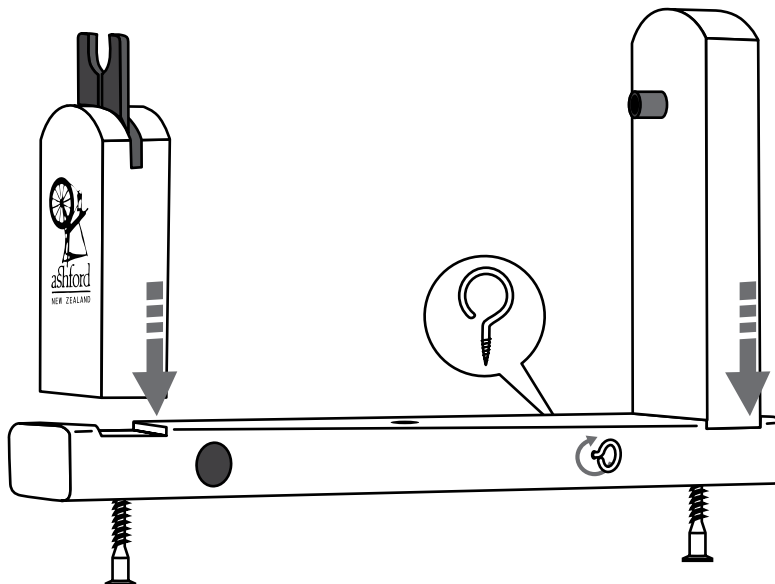
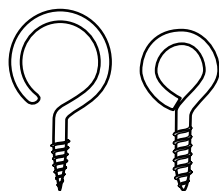

19



Place the maiden bar onto the dowels in the main upright and secure with a 50mm (2") bolt and barrel nut.

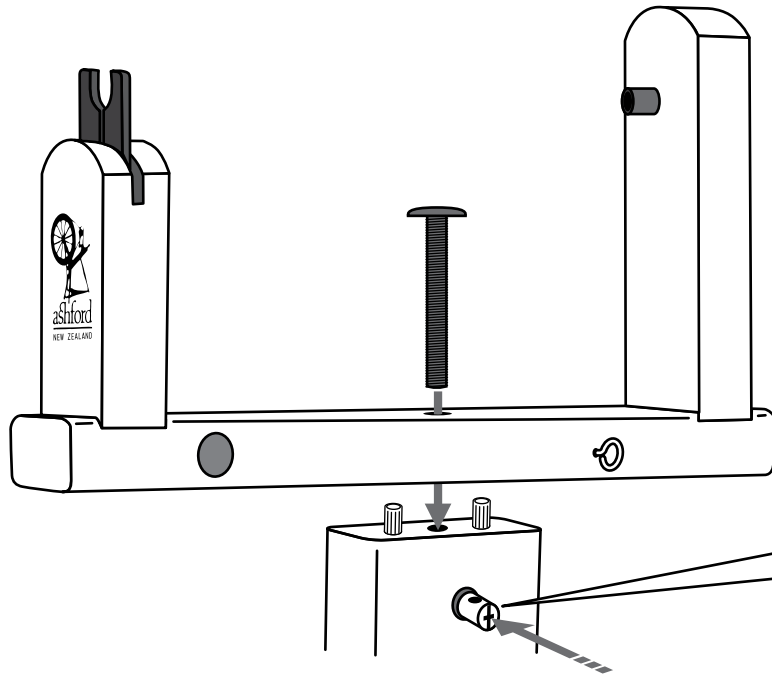
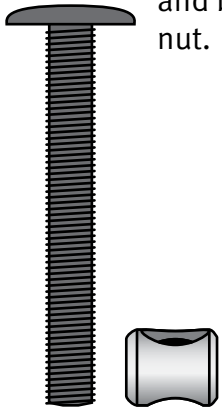

20

Insert the end of the flyer shaft into the rear flyer bearing and click the flyer orifice into the front flyer bearing.

Tie the nylon brake band to spring ①. Thread the nylon brake band through the eye and tie spring ② 35cm (13 3/4") from spring ①, then cut the surplus nylon off and tie it to the other end of spring ②.

Take the nylon brake band up and over the groove in the bobbin and place spring ① onto the hook. Insert the tension knob into the maiden bar, thread the end of the nylon brake band through the hole in the tension knob and tie a knot. Turn the tension knob to wind on excess nylon.



Take care not to over-stretch the springs.

x2

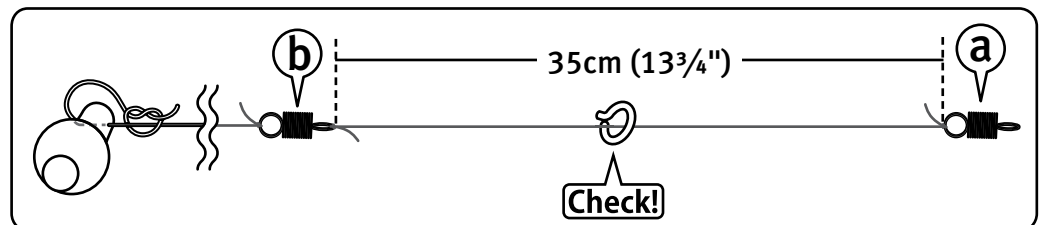
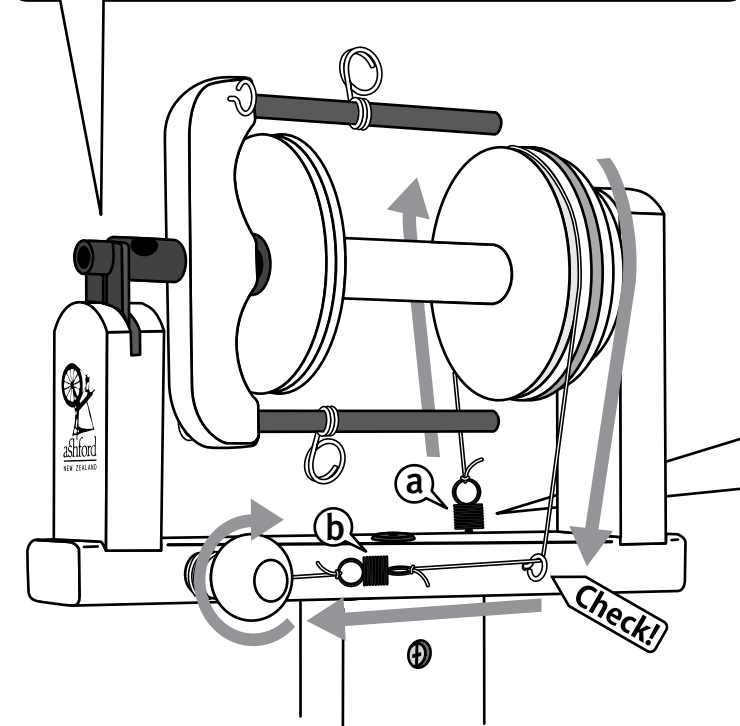
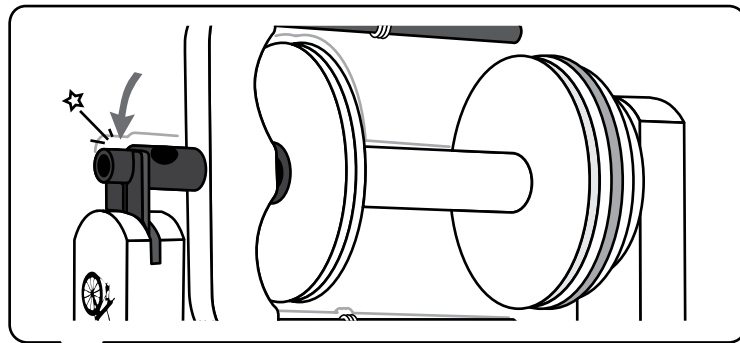

21



Gently tap the lazy kate pins into the base and locate the bobbins on them for storage and plying. Stop tapping when the pins reach the bottom of the holes.

Check!

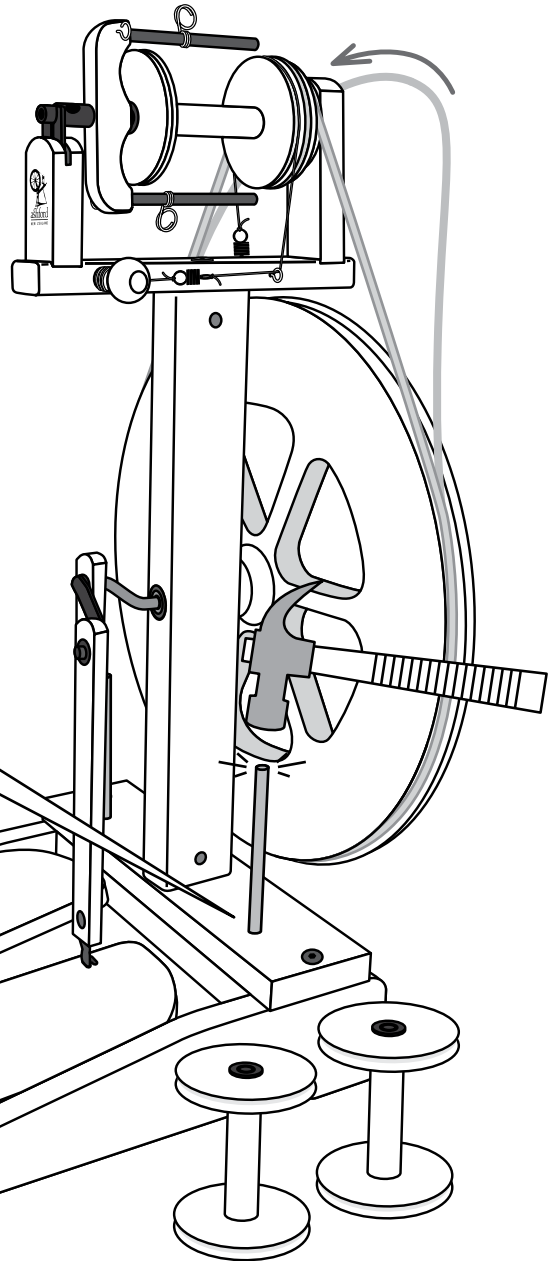
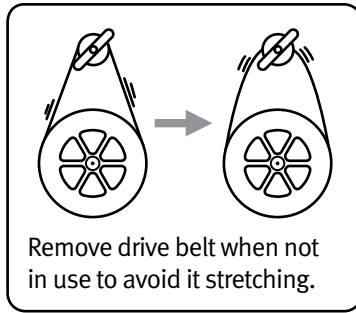

22

Locate the drive band around the large flyer whorl & small groove in the wheel. This gives a flyer to wheel ratio of 5.5:1. For a higher flyer speed, locate the drive band on the small flyer whorl & large groove in the wheel. This gives a flyer to wheel ratio of 7.25:1.

Check!

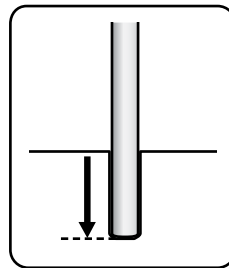

23

Tie the 2 ends of the tape together, loop it through the threading hook and hang it on the tension knob.

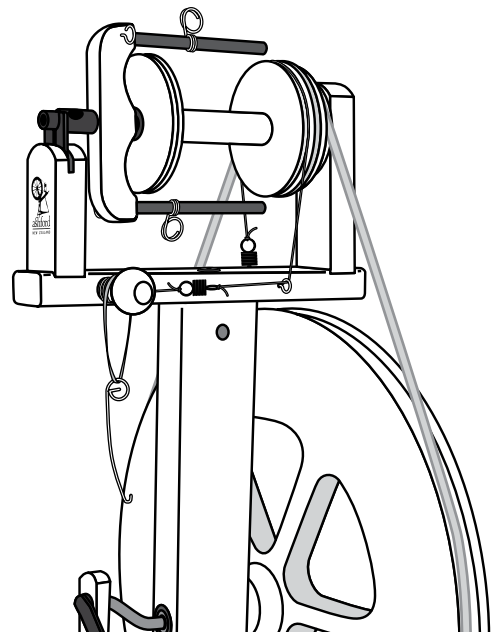
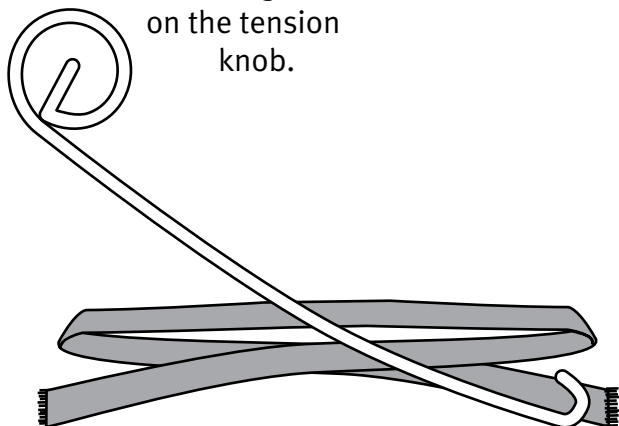

24



To make spinning easier
apply a drop of Ashford
Spinning Wheel Oil to
the flyer, bobbin and
conrod bearings.

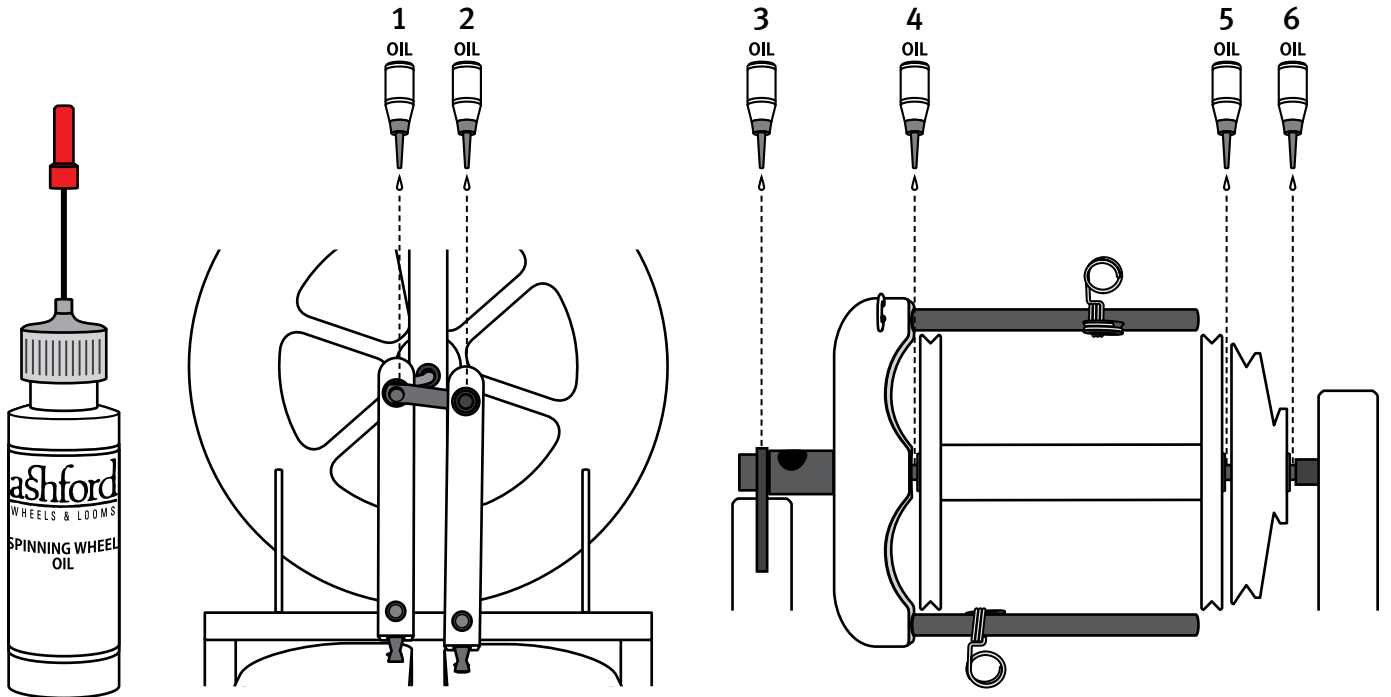

Happy Spinning!

Memo

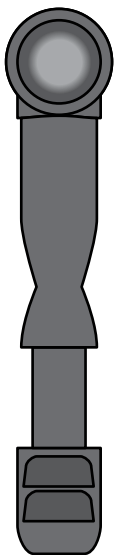

How to insert the polyurethane conrod joints into the conrod.

*This has been pre-assembled in the factory.

1

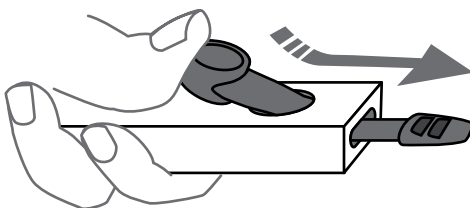

2

